



# Industrial power brushes

8



8



# Industrial power brushes

## Table of contents

General information	4
Filament materials and their application	5
The fast way to the best tool	6
Safety notes and dimensions	8
Cutting speeds and recommendations for use	9
Information on processing stainless steel (INOX)	10
Well packed and presented	11

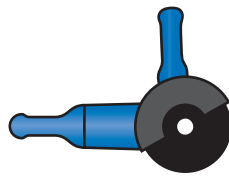

Cup and bevel brushes

12

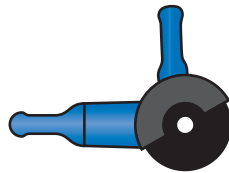
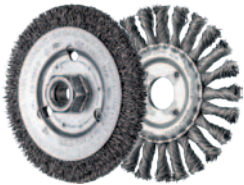

Wheel brushes

17

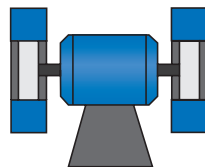
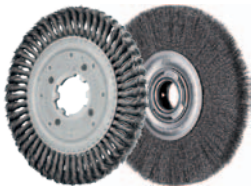

Wheel brushes with arbor hole

21

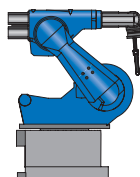

Composite brushes

27

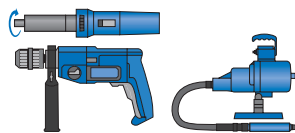

Shank-mounted brushes

32

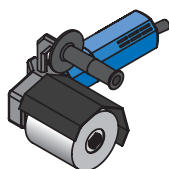

Wheel brushes for burnishing machines

41

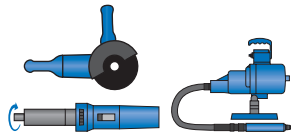
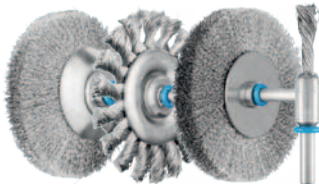

**INOX-TOTAL**

**42**

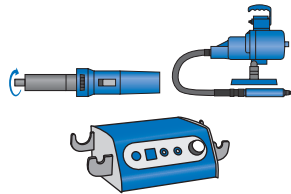

**Miniature brushes**

**45**

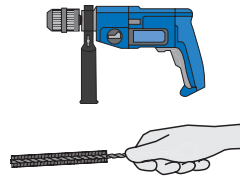
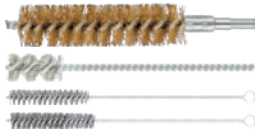

**Tube brushes**

**48**

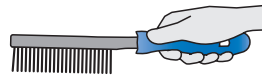

**Scratch brushes**

**53**

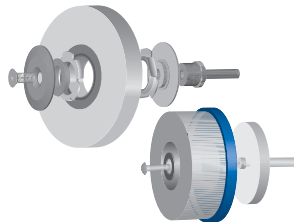
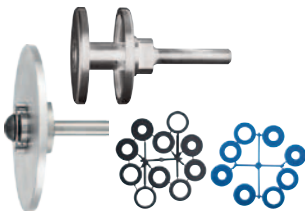

**Accessories**

**55**

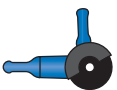

Angle grinder



Burnishing machine/  
drum grinder

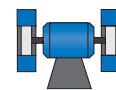

Machine tools

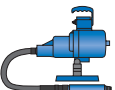

Flexible shaft drive

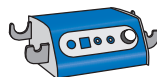

Micro motor

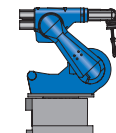

Robot



Power drill



Straight grinder



All tools  
and more information:  
[www.pferd.com](http://www.pferd.com)

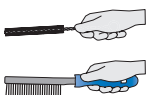

Manual application





# Industrial power brushes

## General information

Industrial power brushes from PFERD are top-quality tools for work on surfaces. PFERD offers a wide range of high-quality brushes for professional work on a large variety of materials and for many different applications. PFERD always has the right brush for any use, any application problem and any material.

The quality of PFERD tools has been certified according to ISO 9001.

### Advantages:

- Long tool life due to PFERD special wires with high flexibility and bending fatigue strength.
- High concentricity due to even distribution and secure fixing of the filament material.
- Optimum finishing result due to close matching of main body and visible trim length.

### PFERD knotted wheel and bevel brushes

are manufactured using a special production process. The special fixing of the brush knots significantly improves performance.

### Advantage:

- Greater efficiency due to 25 % longer tool life compared with conventional knotted brushes.



## Ordering note

When ordering, please state the EAN or the complete description.

**Ordering example:**  
EAN 4007220153017  
RBU 3006/6 ST 0.20

### Ordering example explanation:

RBU = Wheel brush, crimped  
30 = Brush dia. D [mm]  
06 = Filament width  $W_f$  [mm]  
/6 = Shank dia.  $D_s$  [mm]  
ST = Filament material steel  
0.20 = Filament material dia.  $D_f$  [mm]

## Customer support

Your PFERD representative can visit you to offer free and non-binding advice and will be happy to help resolve your application problem and answer any questions about using PFERD brushes safely.

## Products made to order

If you cannot find the solution for your particular application in our extensive catalogue range, we can produce brushes in premium PFERD quality specifically for your application on request. Products that can be made to order include different wire thicknesses and qualities, arbor holes or threads and other dimensions.

## PFERDVALUE – Your added value with PFERD

Results from the PFERD test laboratories as well as from the product tests by independent testing institutes prove: PFERD tools offer measurable added value.

Discover **PFERDERGONOMICS** and **PFERDEFFICIENCY**:

As part of **PFERDERGONOMICS**, PFERD offers ergonomically optimized tools and tool drives that contribute to greater safety and working comfort, and thus to health protection.

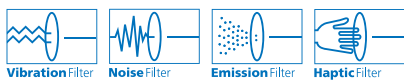

As part of **PFERDEFFICIENCY**, PFERD offers innovative, high-performance tool solutions and tool drives with outstanding added value.



For more information on this topic, please refer to our brochure "**PFERDVALUE – Your added value with PFERD**".

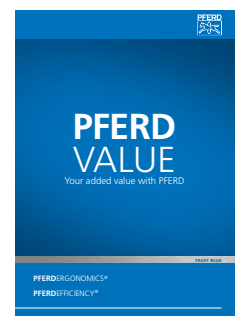

## The fast way to the best tool

To help you find the optimum tool for your needs easily, we have summarized the appropriate brushes for the most important applications on pages 6 to 7.

### ① Select the filament material

The material that you are working with is key to determining the optimum filament material.

Steel wire	–	grey
Stainless steel wire	–	blue
Plastic filament	–	red
Brass wire	–	yellow
Natural bristles	–	brown

### ② Select the filament type

The brushing effect you want determines which filament type to choose.

### ③ Select the tool

The application and geometry of the work-piece indicate the optimum brush.

Industrial power brushes are mainly used for:

- **Deburring**
  - Especially removal of secondary burrs produced by milling, grinding, turning or drilling
- **Cleaning**
  - Derusting, descaling
  - Work on weld seams
  - Cleaning, removal of paint
- **Structuring surfaces**
  - Matt finishing, satinizing
  - Roughening



### Wire filament

- **Crimped brushes (wavy wire):** For work with particular requirements on the flexibility of the brushes, such as machining of highly contoured workpieces.
- **Knotted brushes (straight wire):** For work that requires aggressive brushing behaviour, such as work on weld seams.

Filament material	Temperature resistance	Advantages/properties
Steel wire (ST)	up to 300°C	<ul style="list-style-type: none"> <li>■ PFERD special wire with high tensile strength and bending fatigue strength.</li> <li>■ Guarantees long tool life, even when used for extreme brushing applications.</li> </ul>
Stainless steel wire (INOX)	up to 450°C	<ul style="list-style-type: none"> <li>■ Wire quality 1.4310 (V2A): stainless; does not leave corroding residues on the workpiece.</li> <li>■ Used with low rotational speeds, compared to steel wire.</li> <li>■ PFERD brushes with INOX filament are usually degreased.</li> </ul>
Stainless steel wire (INOX)/Diamond (DIA)		<ul style="list-style-type: none"> <li>■ Particularly well suited to applications that place particular demands on the aggressiveness of the brush.</li> <li>■ Primarily used on materials with high material strength.</li> </ul>
Further information about working with stainless steel (INOX) can be found on page 10.		
Brass wire (MES)	up to 180°C	<ul style="list-style-type: none"> <li>■ Wire quality CuZn37: brass wire is softer than steel wire.</li> <li>■ It is non-sparking and produces fine surface finishes.</li> </ul>

### Plastic filament

- Abrasive grains are embedded in flexible plastic filaments, which means that the filament works on the sides as well as at the tip.
- **Round filament:** for applications that place particular demands on the flexibility of the brush.
- **Rectangular filament (REC):** for applications that place particular demands on the aggressiveness of the brush.
- Recommendation for use: Use coolant for applications where large amounts of heat are produced.

Filament material	Temperature resistance	Advantages/properties
Silicon carbide (SiC)	up to 220°C	<ul style="list-style-type: none"> <li>■ Particularly well suited to deburring work and for improving surfaces.</li> </ul>
Aluminium oxide (AO)		<ul style="list-style-type: none"> <li>■ Less sharp-edged and aggressive compared with SiC.</li> <li>■ Primarily suitable for polishing and smoothing for finishing on soft metals.</li> </ul>
Ceramic oxide grain (CO)		<ul style="list-style-type: none"> <li>■ Offers good toughness and excellent sharpness.</li> <li>■ For high stock removal values and aggressive brushing behaviour.</li> </ul>
Diamond (DIA)		<ul style="list-style-type: none"> <li>■ Particularly well suited to applications that place particular demands on the aggressiveness of the brush.</li> <li>■ Primarily used on materials with high material strength.</li> </ul>
Nylon		<ul style="list-style-type: none"> <li>■ Particularly suited to working with materials that would otherwise be scratched or damaged, e.g. soft plastics.</li> </ul>

### Natural bristles (animal hair)

- Primarily suitable for light cleaning and dust removal, as well as for polishing (in combination with polishing pastes).

Filament material	Temperature resistance	Advantages/properties
White (SBW) and black (SBS) bristles	up to 150°C	<ul style="list-style-type: none"> <li>■ Bristles are harder and less flexible than brushes with goat hair filaments.</li> </ul>
Goat hair (ZHW)		

### Selecting the filament material

Filament material	Material that can be worked						
	Steel	Stainless steel (INOX)	Non-ferrous metals			Cast iron	Plastics
			Aluminium	Soft non-ferrous metals Brass, copper, zinc	Hard non-ferrous metals Titanium, bronze, nickel-based and cobalt-based alloys		
Steel wire (ST)	●	-	-	-	-	●	○
Stainless steel wire (INOX)	○	●	●	○	○	-	-
Stainless steel wire (INOX) Diamond (DIA)	○	-	-	-	●	●	●
Brass wire (MES)	-	-	-	●	-	-	-
Silicon carbide (SiC)	●	●	●	-	○	●	●
Aluminium oxide (AO)	○	○	●	-	-	○	○
Ceramic oxide grain (CO)	●	○	○	-	●	●	-
Diamond (DIA)	○	-	-	-	●	●	●
Nylon	-	-	○	○	-	-	●
Bristle and goat hair (with polishing paste)	●	●	●	●	●	●	●

● = highly suitable    ○ = suitable    - = not suitable











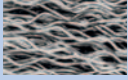

























































# Industrial power brushes

The fast way to the best tool



Materials that can be worked	Steel, cast iron, plastics			Stainless steel (INOX), aluminium, other non-ferrous metals
Filament material	Steel wire (ST) Colour code: grey			Stainless steel wire (INOX) Colour code: blue
Filament type				
Desired effect	knotted	crimped	encapsulated	knotted
Weld seam	Aggressive brushing effect, less flexible	Light brushing effect, flexible	Very aggressive brushing effect, not flexible	Aggressive brushing effect, less flexible
	 RBG p. 18–19  RBG PIPE p. 20–21	 HBU p. 53  HBK p. 53	 RBV p. 39	 RBG p. 18–19  RBG PIPE p. 20–21
		 RBU p. 22–26  RBU SC p. 17  WBU p. 41		
	 KBG p. 15–16  RBG p. 18–19  RBG p. 40	 KBU p. 15, 37  RBU p. 17, 22, 24–26  RBU p. 38  RBU p. 47	 RBV p. 39	 KBG p. 15–16  RBG p. 18–19  RBG p. 40
	 TBG p. 13–14	 TBU p. 12  TBU p. 36		 TBG p. 13–14
	 PBG p. 35	 PBU p. 32–34  PBU p. 45  TBU p. 46  IBU p. 48, 50, 52	 PBV p. 33	 PBG p. 35
	 TBG p. 13–14  KBG p. 15–16  RBG p. 18–19	 TBU p. 12  KBU p. 15, 37  RBU p. 38  HBU p. 53		 TBG p. 13–14  KBG p. 15–16  RBG p. 18–19
	 RBG p. 40	 RBU p. 22–26		 RBG p. 40
	 PBG p. 35	 PBU p. 32–34  PBU p. 45  TBU p. 46  IBU p. 48, 50, 52	 PBV p. 33	 PBG p. 35
				

Stainless steel (INOX), aluminium, other non-ferrous metals	Steel, stainless steel (INOX), aluminium, non-ferrous metals, titanium, cast, plastics, wood	Brass, copper, other non-ferrous metals	Steel, stainless steel (INOX), non-ferrous metals, cast iron
Stainless steel wire (INOX) Colour code: blue	Plastic filament (SiC, CO, nylon) Colour code: red	Brass wire (MES) Colour code: yellow	Natural materials Colour code: brown
 crimped	 crimped	 crimped	 crimped
Light brushing effect, flexible	Grinding brushing effect, very flexible	Light brushing effect, flexible	Light brushing effect (use with polishing pastes)
 HBU p. 53	 HBK p. 53	 HBU p. 53	
 RBU p. 17, 22, 24-26	 WBW p. 41		
 RBU p. 22-24, 26	 RBUP p. 27-28	 WBU p. 41	
 KBU p. 15, 37	 RBU p. 22, 24-26	 RBU p. 38	 RBU p. 47
 RBU p. 22-24, 26	 RBUP p. 27-28	 RBU p. 39	 RBU p. 47
 RBU p. 38	 RBU p. 47		
 TBU p. 12	 TBU p. 36	 TBU p. 12	 DBU p. 29-30
 TBU p. 36			
 PBU p. 32-34	 PBU p. 45	 TBU p. 46	 IBU p. 48, 50, 52
 PBU p. 31-32	 PBU p. 45	 TBU p. 46	 IBU p. 48, 51-52
 PBU p. 32	 PBU p. 45	 TBU p. 46	 IBU p. 48, 50, 52
 TBU p. 12	 KBU p. 15, 37	 RBU p. 38	 HBU p. 53
 TBU p. 12	 RBU p. 22-24, 26	 RBUP p. 27-28	 DBU p. 29-30
 RBU p. 38	 HBU p. 53		
 RBU p. 17, 22, 24-26	 TBU p. 36	 RBU p. 39	
 PBU p. 32-34	 PBU p. 45	 TBU p. 46	 IBU p. 48, 50, 52
 PBU p. 31-32	 PBU p. 45	 TBU p. 46	 IBU p. 48, 51-52
 PBU p. 32	 IBU p. 48, 50, 52	 PBU p. 45	 TBU p. 46
		 RBU p. 47	 PBU p. 45
		 TBU p. 46	



# Industrial power brushes

## Safety notes and dimensions

### PFERD – safe tools are our speciality

PFERD industrial power brushes meet a high standard of quality and safety, which is constantly monitored and further developed in our own laboratories. As one of the leading manufacturers of brush tools, PFERD fulfils the requirements of European standard EN 1083.

Guidelines on the safe and economic use of PFERD brushes are supplied with every packaging unit. They help you to increase your level of personal work safety.



### Safety notes:



= Wear eye protection!



= Wear hearing protection!



= Wear a dust mask!



= Wear gloves!



= Read the safety notes!



= Use a protective machine cover!

#### Maximum permitted rotational speed

In order to guarantee operating safety, the maximum permitted rotational speed indicated on the brush, label and in this catalogue must never be exceeded!

Please refer to our product information and product tables for further recommendations regarding optimum operating speeds. These give details of the recommended rotational speeds [RPM] for an optimum working result.

#### Brush diameter

In the case of hand-held tool drives, the brush diameter should never exceed 180 mm, regardless of the filament material.

#### Minimum arbor hole diameter according to EN 1083

Brushes must comply with the minimum arbor hole diameters ( $D_A$ ) listed below, depending on their total diameter (D).

Total dia. D of the brush [mm]	Minimum arbor hole dia. $D_A$ [mm]
50	4.6
75	6.5
100	10
150	13
200	16
250	20
300	20
350	32

### Explanation of dimensions

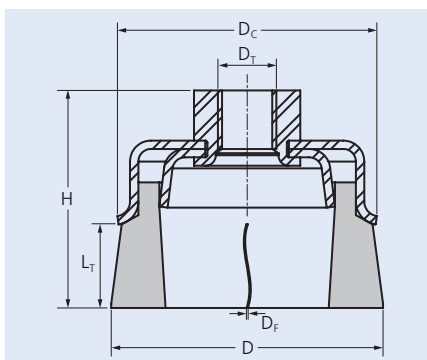
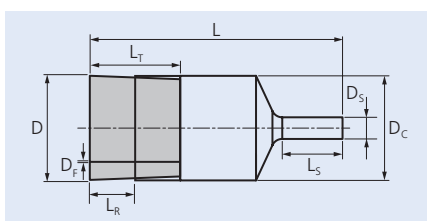
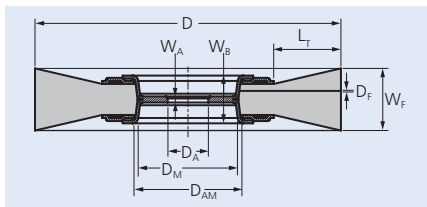

Abbreviation	Unit	Description
D	mm	Nominal outer diameter of the brush or the working surface for end brushes
$D_A$	mm	Hole diameter
$D_{AM}$	mm	Max. hole diameter in main body
$D_C$	mm	Max. diameter of the main body
$D_F$	mm	Nominal dimension of the filament material (wire thickness)
$D_M$	mm	Diameter in hole area
$D_S$	mm	Shank diameter in shank-mounted brushes, shaft diameter for wheel brushes for burnishing machines, stem diameter (core) for pipe brushes
$D_T$	mm	Nominal thread designation
H	mm	Nominal total height (incl. components for arbor hole or thread as well as shank)
L	mm	Nominal total length for end brushes (without guide pins) and pipe brushes
$L_S$	mm	Usable length for shank or stem, total length of the mounting shaft, usable thread length
$L_T$	mm	Nominal length of the filament material (free length of the filament material)
$L_R$	mm	Total length of the filament material (free length without bridle)
$W_A$	mm	Width of the main body at the hole / thread
$W_B$	mm	Installation width, widest point of the main body
$W_F$	mm	Nominal dimensions of the working width

### Determining the recommended rotational speed

- 1 Select brush type.
- 2 Read the recommended cutting speed.
- 3 Determine the rotational speed using the brush diameter and cutting speed.

The recommended cutting speed ranges [m/s] depend on the respective application and lie below the maximum permitted cutting speed.

1 Brush type	2 Cutting speed
End brushes	5-15 m/s
Cup brushes	15-45 m/s
Shank-mounted wheel brushes	15-40 m/s
Wheel/bevel brushes with arbor hole/threaded	See diagram below

### Recommendations for use:

#### Contact pressure and working position



Incorrect (1) Correct (2)  
Only use the wire tips (Fig. 2).

#### Exception

In the case of brushes with plastic filament material, it is not only the wire tips that can be used, but 2-3 mm of the filaments. In the case of stationary brushes, machining should be carried out under the middle of the brush (see Fig. 2).

#### Visible trim lengths

Short visible trim lengths give a stiffer trim surface, resulting in more aggressive brushing action. Longer trim lengths are more flexible, giving a softer brush performance that produces a more uniform finish, even on irregular surfaces.

#### Self-sharpening effect

The self-sharpening effect can be improved during use by changing the brush operating direction.

#### Filament diameters

##### Thick filament

■ An aggressive brushing effect with a coarse surface finish, as fewer wire tips are in contact with the surface of the workpiece at the same time.

##### Thin filament

■ A soft brushing effect with a fine surface finish, as many wire tips are in contact with the surface of the workpiece at the same time.

■ A longer tool life for the brush due to the higher level of flexibility of the filaments.

### 2 Recommended cutting speed [m/s] for wheel/bevel brushes with arbor hole/threaded

Application	[m/s]	10	15	20	25	30	35	40	45	50	55
Deburring/ edge breaking	knotted							35-45 m/s			
							30-40 m/s				
	crimped				25-40 m/s						
				15-30 m/s							
Removal of scale/ mill scale	knotted							35-55 m/s			
							30-40 m/s				
Cleaning/ roughening of surfaces	knotted							35-40 m/s			
							30-35 m/s				
	crimped				20-40 m/s						
				15-35 m/s							
Weld dressing	knotted							35-55 m/s			
							30-40 m/s				
	crimped								30-45 m/s		
							25-40 m/s				

The colour bars correspond to the colour codes of the filament materials (see page 4).

### 3 Recommended rotational speeds [RPM]

n [RPM]	Brush dia. D [mm]																	
	10	15	20	25	30	40	50	60	75	80	100	115	125	150	175	200	250	300
1,000	1	1	1	1	2	2	3	3	4	4	5	6	7	8	9	10	13	16
1,250	1	1	1	2	2	3	3	4	5	5	7	8	8	10	11	13	16	20
1,500	1	1	2	2	3	4	5	6	6	8	9	10	12	14	16	20	24	27
1,750	1	1	2	2	3	4	5	6	7	7	9	11	11	14	16	18	23	27
2,000	1	2	2	3	3	4	5	6	8	8	10	12	13	16	18	21	26	31
2,500	1	2	3	3	4	5	7	8	10	10	13	15	16	20	23	26	33	39
3,000	2	2	3	4	5	6	8	9	12	13	16	18	20	24	27	31	39	47
3,500	2	3	4	5	5	7	9	11	14	15	18	21	23	27	32	37	46	55
4,000	2	3	4	5	6	8	10	13	16	17	21	24	26	31	37	42	52	63
4,500	2	4	5	6	7	9	12	14	18	19	24	27	29	35	41	47	59	71
5,000	3	4	5	7	8	10	13	16	20	21	26	30	33	39	46	52	65	79
5,500	3	4	6	7	9	12	14	17	22	23	29	33	36	43	50	58	72	87
6,000	3	5	6	8	9	13	16	19	24	25	31	36	39	47	55	63	79	96
6,500	3	5	7	9	10	14	17	20	26	27	34	39	43	51	60	68	86	104
7,000	4	5	7	9	11	15	18	22	27	29	37	42	46	55	64	73	92	111
7,500	4	6	8	10	12	16	20	24	29	31	39	45	49	59	69	79	100	121
8,000	4	6	8	10	13	17	21	25	31	34	42	48	52	63	73	84	106	128
10,000	5	8	10	13	16	21	26	31	39	42	52	60	65	79	91	104	129	156
12,000	6	9	13	16	19	25	31	38	47	50	63	72	79	95	110	126	154	183
14,000	7	11	15	18	22	29	37	44	55	59	73	83	91	110	127	146	176	207
16,000	8	13	17	21	25	34	42	50	63	67	83	94	103	124	143	164	196	230
20,000	10	16	21	26	31	42	52	63	79	84	104	117	128	152	174	198	234	274
22,000	12	17	23	29	35	46	58	69	87	92	113	127	139	165	188	214	252	294
25,000	13	20	26	33	39	52	65	79	99	105	127	142	155	183	208	236	276	320

Example:

RBG 11512 ST

Cleaning surfaces

Brush dia. D: 115 mm

Cutting speed: 39 m/s

Rotational speed: 6,500 RPM

$$\text{Cutting speed (v)} = \frac{\text{dia. (D)} \times \pi \times \text{rot. speed (n)}}{1,000 \times 60}$$

### Solutions to problems

Problems	Possible solutions
Inadequate brushing effect	<ul style="list-style-type: none"> <li>■ Increase rotational speed or use larger brush diameter at the same rotational speed.</li> <li>■ Choose a brush with shorter trim length.</li> <li>■ Use a brush with thicker filaments.</li> </ul>
Brushing effect too great	<ul style="list-style-type: none"> <li>■ Reduce rotational speed or use smaller brush diameter at the same rotational speed.</li> <li>■ Reduce the contact pressure.</li> <li>■ Choose a brush with longer trim length.</li> <li>■ Use a brush with thinner filaments.</li> </ul>
Surface is too rough and irregular	<ul style="list-style-type: none"> <li>■ Use a wider brush.</li> <li>■ Use a brush with thinner filaments.</li> <li>■ Reduce the rotational speed.</li> </ul>
Surface is too finely polished and shiny	<ul style="list-style-type: none"> <li>■ Use a brush with thicker filaments.</li> <li>■ Choose a brush with shorter trim length.</li> <li>■ Reduce the rotational speed.</li> </ul>
Secondary burr formation	<ul style="list-style-type: none"> <li>■ Change the working position of the brush in relation to the workpiece.</li> <li>■ Choose a brush with shorter trim length.</li> <li>■ Use a brush with thicker filaments.</li> </ul>



# Industrial power brushes

## Information on processing stainless steel (INOX)

### Expertise in working with stainless steel (INOX)

PFERD offers an extensive range of tools that meets the demands of working with stainless steel (INOX).



The PRAXIS brochure "PFERD tools for use on stainless steel (INOX)" contains much valuable information on material properties and application recommendations.

### PFERD wire qualities

In order to fulfil the particular requirements for working with stainless steel (INOX), PFERD uses wire quality 1.4310 (V2A) for all INOX brushes. Practical experience from industry has shown that this offers excellent corrosion resistance with an optimum tool life.

All PFERD brushes with INOX filaments are colour-coded in blue and are suitable for use on all stainless steels (INOX), such as V4A.

#### INOX and magnetism

The wire quality 1.4310 tends to become ferromagnetic in the case of cold working; i.e. it can be attracted using magnets. The reason for this is a change in the microstructure caused by deformation (e.g. during the wire drawing process). This does not have any impact on the quality and corrosion resistance of the INOX filament. The filament is still resistant to corrosion.

AISI	Code acc. to EN 10027-1	Material no. acc. to EN 10027-2
304	X5CrNi18-10	1.4301 (V2A)
301	X10CrNi18-8	1.4310 (V2A)
316	X5CrNiMo17-12-2	1.4401 (V4A)
316	X3CrNiMo17-13-3	1.4436 (V4A)
316Ti	X6CrNiMoTi17-12-2	1.4571 (V4A)

### INOX-TOTAL brushes

For extremely difficult operating conditions, PFERD offers a range of "INOX-TOTAL" (IT) brushes. These are characterized by the fact that all parts of the brush are made of stainless steel in quality 1.4310 (V2A), which ensures optimum corrosion protection. Detailed information and ordering data can be found on pages 42–44.



### Recommendations for avoiding corrosion

Cause of corrosion	Solution
Change in the microstructure due to too much heat build-up.	Avoid heat build-up through: <ul style="list-style-type: none"> <li>■ Lower rotational speed</li> <li>■ Reduced contact pressure</li> <li>■ Oscillating brushing</li> </ul>
Contact between the workpiece and the parts of the brush that are made of steel.	<ul style="list-style-type: none"> <li>■ Use INOX-TOTAL type brushes.</li> <li>■ Avoid contact between the face plates and workpiece.</li> <li>■ Use end brushes with plastic protection.</li> </ul>
Mixture of work on steel and stainless steel (INOX).	<ul style="list-style-type: none"> <li>■ Do not use brushes that have already been used to work on steel, copper or other metals.</li> <li>■ Do not work on steel in the vicinity of stainless steel (INOX) applications.</li> </ul>
Wire particles are introduced into the surface (crevice corrosion).	<ul style="list-style-type: none"> <li>■ Avoid a high contact pressure.</li> <li>■ Use a low rotational speed.</li> </ul>
Stock removal rate is too low.	Removal of deep structural changes by: <ul style="list-style-type: none"> <li>■ Extending the brushing time</li> <li>■ Using grinding tools</li> </ul>

#### Note

To avoid possible problems, it makes sense to run preliminary tests to check the corrosion resistance of the workpiece. General cleaning of the workpieces after brushing is recommended in order to prevent loose particles sticking to the workpiece.

For workpieces that are used in a heavily corrosive environment, processing with grinding tools and etching or passivation is recommended. This also applies when not only stainless steel (INOX) but also non-alloyed steels are processed and it cannot be completely ruled out that abrasion particles will land on the stainless steel.



For detailed information and ordering data for fine grinding and polishing tools, please see catalogue section 4.



**Industrial packaging**

PFERD provides industrial brushes in industrial packaging as standard.



This symbol indicates all brushes in industrial packaging (IP).

**Advantages:**

- Robust, damage-resistant packaging.
- Packaging label containing all the important information such as item number, description, EAN code and technical details.
- Information on safe use of brushes included in each packaging unit.



**POS packaging**

PFERD provides wheel, cup, end and bevel brushes in sales-boosting individual packaging. Individually packed shank brushes are supplied in a practical cardboard box.



This symbol and the addition of "POS" in the description are used to indicate all brushes in POS packaging.

An overview of all brushes in POS packaging is available here: [www.pferd.com/pos-brushes](http://www.pferd.com/pos-brushes)

**Advantages:**

- Functional European standard hole mounting for optimum product presentation on the sales wall.
- Packaging label containing all the important information such as item number, description, EAN code and technical details.
- Product is easily recognizable through the viewing window.



**PFERD TOOL-CENTER**

You will find all the important information required in order to select the most appropriate tool on the **PFERD TOOL-CENTER**.

Your local retailer or PFERD sales representative will be glad to answer any questions you might have. To find an expert PFERD retailer near you, visit: [www.pferd.com](http://www.pferd.com)



**Packaging label**

The packaging label provides all the important information: item number, description, EAN code and technical details.

**Advantages:**

- Quick identification of the key product features due to symbols.
- Information on safe and optimum use of the brush.

Filament material

Packaging unit

Tool type

PFERD description

Technical information



# Threaded cup brushes

## crimped

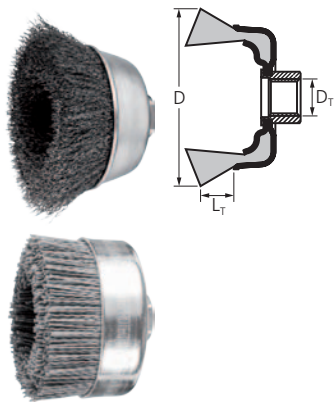

### TBU

Excellent for medium-duty brushing such as deburring, cleaning and derusting on large surfaces.



#### Advantages:

- Highly flexible, enabling optimal adjustment to the workpiece contour.
- Creates fine surfaces.

#### Recommendations for use:

- For optimum results, use on speed-adjustable angle grinders.

#### Ordering notes:

- For the 5-piece packaging unit, please specify the description without "POS".

D [mm]	L <sub>T</sub> [mm]	D <sub>T</sub>	D <sub>F</sub> [mm]	Packaging		Opt. RPM	Max. RPM	Description
				1	5			
				EAN 4007220				

#### Steel wire (ST)

60	20	M14x2	0.30	153543	955192	6,300–9,400	12,500	POS TBU 60/M14 ST 0,30
75	25	M14x2	0.30	220849	955208	6,300–9,400	12,500	POS TBU 75/M14 ST 0,30
100	25	M14x2	0.30	153574	-	4,300–6,400	8,500	POS TBU 100/M14 ST 0,30

#### Stainless steel wire (INOX)

All INOX brushes are degreased.

60	20	M14x2	0.30	721742	955215	5,000–8,100	12,500	POS TBU 60/M14 INOX 0,30
75	25	M14x2	0.30	220856	955222	5,000–8,100	12,500	POS TBU 75/M14 INOX 0,30
100	25	M14x2	0.30	220863	-	3,400–5,500	8,500	POS TBU 100/M14 INOX 0,30

#### Silicon carbide (SiC) plastic filament

100	46	M14x2	1.00	530856	-	2,400–3,900	6,000	POS TBU 100/M14 SiC 120 1,00
-----	----	-------	------	--------	---	-------------	-------	------------------------------



### TBG

Aggressive brush. Excellent for heavy-duty brushing such as deburring, cleaning and derusting on large surfaces.

#### Advantages:

- Aggressive brushing effect due to the very stiff wire knots.



#### Recommendations for use:

- For optimum results, use on powerful angle grinders.

#### Ordering notes:

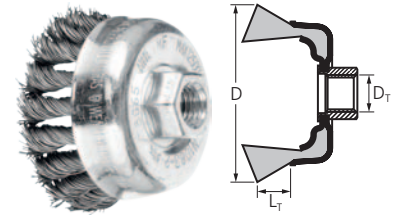
- For the 5-piece packaging unit, please specify the description without "POS".
- DIA type brushes are supplied with 1 piece per PU.
- Grit size DIA 270 = D 64, grit size DIA 400 = D 46



D [mm]	L <sub>T</sub> [mm]	D <sub>T</sub>	D <sub>F</sub> [mm]	Knots [pcs.]	Packaging		Opt. RPM	Max. RPM	Description
									
					EAN 4007220				

#### Steel wire (ST)

65	22	M14x2	0.35	18	153437	955079	6,300–12,500	12,500	POS TBG 65/M14 ST 0,35
			0.50	18	579121	955086	6,300–12,500	12,500	POS TBG 65/M14 ST 0,50
			0.80	18	579138	-	6,300–12,500	12,500	POS TBG 65/M14 ST 0,80
80	20	M14x2	0.50	20	806654	955093	5,000–10,000	10,000	POS TBG 80/M14 ST 0,50
100	25	M14x2	0.50	24	806661	955109	4,500–9,000	9,000	POS TBG 100/M14 ST 0,50

#### Stainless steel wire (INOX)

All INOX brushes are degreased.

65	22	M14x2	0.35	18	220740	955116	5,000–12,500	12,500	POS TBG 65/M14 INOX 0,35
			0.50	18	598016	955123	5,000–12,500	12,500	POS TBG 65/M14 INOX 0,50
80	20	M14x2	0.35	20	806678	955130	4,000–10,000	10,000	POS TBG 80/M14 INOX 0,35
			0.50	20	003671	003688	4,000–10,000	10,000	POS TBG 80/M14 INOX 0,50
100	25	M14x2	0.35	24	806685	955147	3,600–9,000	9,000	POS TBG 100/M14 INOX 0,35
			0.50	24	003701	003718	3,600–9,000	9,000	POS TBG 100/M14 INOX 0,50

#### Stainless steel wire (INOX) Diamond (DIA)

100	38	M14x2	0.50	24	-	107881	1,000–2,400	9,000	TBG 100/M14 INOX 0,50 DIA 270
					-	107874	1,000–2,400	9,000	TBG 100/M14 INOX 0,50 DIA 400

### TBGR, with bridle

Aggressive brush with bridle. Excellent for heavy-duty brushing such as deburring, cleaning and derusting on large surfaces.

#### Advantages:

- The bridle prevents the wires spreading out sideways.
- Particularly long tool life.
- The bridle enables the spreading out and flexibility of the brush filament to be controlled.

#### Recommendations for use:

- For optimum results, use on powerful angle grinders.
- Remove the bridle once the filament is worn down. Then the rest of the filament can be used.
- Remove the bridle before starting work if you would like to achieve a large spreading diameter or access hard-to-reach areas.

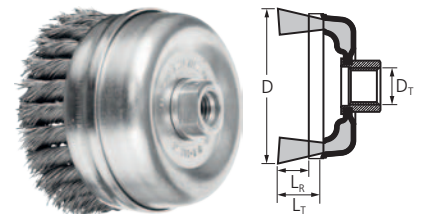

D [mm]	L <sub>R</sub> [mm]	L <sub>T</sub> [mm]	D <sub>T</sub>	D <sub>F</sub> [mm]	Knots [pcs.]	Packaging	Opt. RPM	Max. RPM	Description
									
						EAN 4007220			

#### Steel wire (ST)

80	25	40	M14x2	0.50	22	153482	4,300–8,500	8,500	TBGR 80/M14 ST 0,50
100	25	40	M14x2	0.50	26	153505	4,300–8,500	8,500	TBGR 100/M14 ST 0,50
			5/8-11	0.50	26	598009	4,300–8,500	8,500	TBGR 100/5/8 ST 0,50
125	25	30	5/8-11	0.50	32	584811	3,300–6,500	6,500	TBGR 125/5/8 ST 0,50
150	20	40	5/8-11	0.50	40	584828	2,800–5,500	5,500	TBGR 150/5/8 ST 0,50



# Threaded cup brushes

## knotted

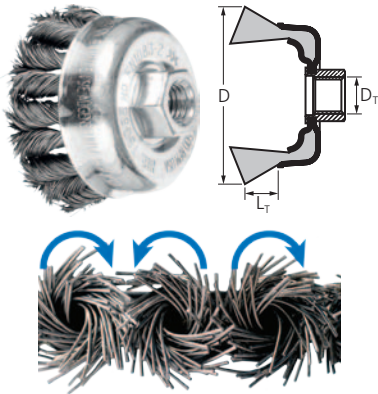

### TBG CT, COMBITWIST

Very aggressive brush. Excellent for heavy-duty brushing such as deburring, cleaning and derusting on large surfaces.

#### Advantages:

- Maximum economic efficiency due to the longest tool life and the highest stock removal.
- High level of comfort thanks to smooth running with no brush recoiling.
- Suitable for work on corners and edges as the knots are less likely to unravel.

#### Recommendations for use:

- For optimum results, use on powerful angle grinders.

#### Ordering notes:

- For the 5-piece packaging unit, please specify the description without "POS".

#### PFERDVALUE:

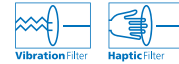

D [mm]	L <sub>T</sub> [mm]	D <sub>T</sub>	D <sub>F</sub> [mm]	Knots [pcs.]	Packaging		Opt. RPM	Max. RPM	Description
					1	5			
EAN 4007220									

#### Steel wire (ST) – COMBITWIST type

65	22	M14x2	0.35	18	806692	955154	6,300–12,500	12,500	POS TBG 65/M14 CT ST 0,35
			0.50	18	806708	955161			POS TBG 65/M14 CT ST 0,50
80	20	M14x2	0.50	20	806715	955178	5,000–10,000	10,000	POS TBG 80/M14 CT ST 0,50
100	25	M14x2	0.50	24	806722	955185	4,500–9,000	9,000	POS TBG 100/M14 CT ST 0,50

#### Stainless steel wire (INOX) – COMBITWIST type

All INOX brushes are degreased.

65	22	M14x2	0.35	18	806739	-	5,000–12,500	12,500	POS TBG 65/M14 CT INOX 0,35
			0.50	18	806746	-			POS TBG 65/M14 CT INOX 0,50
80	20	M14x2	0.35	20	806753	-	4,000–10,000	10,000	POS TBG 80/M14 CT INOX 0,35
			0.50	20	003695	-			POS TBG 80/M14 CT INOX 0,50
100	25	M14x2	0.35	24	806760	-	3,600–9,000	9,000	POS TBG 100/M14 CT INOX 0,35
			0.50	24	003725	-			POS TBG 100/M14 CT INOX 0,50



## KBU

Excellent for medium-duty brushing such as deburring, cleaning and derusting.

### Advantages:

- Optimal access to hard-to-reach areas such as inner edges, grooves and keyways.
- Suitable for use on angle grinders up to 80 m/s.
- Highly flexible, enabling optimal adjustment to the workpiece contour.
- Creates fine surfaces.

### Recommendations for use:

- For optimum results, use on speed-adjustable angle grinders.

### Ordering notes:

- For the 5-piece packaging unit, please specify the description without "POS".

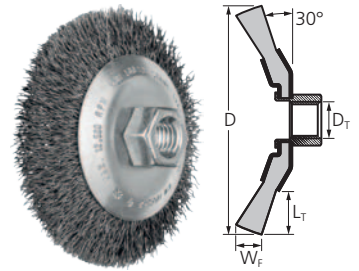

D [mm]	W <sub>F</sub> [mm]	L <sub>T</sub> [mm]	D <sub>T</sub>	D <sub>F</sub> [mm]	Packaging		Opt. RPM	Max. RPM	Description
					1	5			
					EAN 4007220				

### Steel wire (ST)

100	10	22	M14x2	0.35	220832	955314	6,300–12,500	12,500	POS KBU 10010/M14 ST 0,35
115	10	30	M14x2	0.35	806777	-	6,300–12,500	12,500	POS KBU 11510/M14 ST 0,35
125	10	22	M14x2	0.35	-	104736	6,300–11,000	11,000	POS KBU 12510/M14 ST 0,35

### Stainless steel wire (INOX)

All INOX brushes are degreased.

100	10	22	M14x2	0.35	531129	955321	5,000–12,500	12,500	POS KBU 10010/M14 INOX 0,35
115	10	30	M14x2	0.35	806784	-	5,000–12,500	12,500	POS KBU 11510/M14 INOX 0,35
125	10	22	M14x2	0.35	-	104743	5,000–11,000	11,000	POS KBU 12510/M14 INOX 0,35

## knotted

## KBG

Aggressive brush. Excellent for heavy-duty brushing such as deburring, cleaning and derusting.



### Advantages:

- Optimal access to hard-to-reach areas such as inner edges, grooves and keyways.

### Recommendations for use:

- For optimum results, use on powerful angle grinders.

### Ordering notes:

- For the 5-piece packaging unit, please specify the description without "POS".

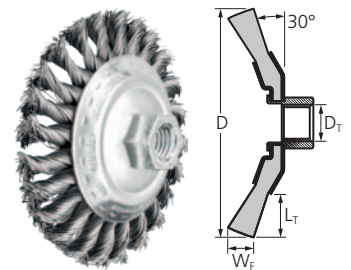

D [mm]	W <sub>F</sub> [mm]	L <sub>T</sub> [mm]	D <sub>T</sub>	D <sub>F</sub> [mm]	Knots [pcs.]	Packaging		Opt. RPM	Max. RPM	Description
						1	5			
						EAN 4007220				

### Steel wire (ST)

100	13	22	M14x2	0.50	22	153529	955239	10,000–15,000	20,000	POS KBG 10013/M14 ST 0,50
115	15	26	M14x2	0.50	22	220818	955246	7,500–12,500	15,000	POS KBG 11515/M14 ST 0,50
125	15	19	M14x2	0.50	28	531167	-	7,500–12,000	15,000	POS KBG 12515/M14 ST 0,50

### Stainless steel wire (INOX)

All INOX brushes are degreased.

100	13	22	M14x2	0.35	22	220801	955253	8,600–15,000	20,000	POS KBG 10013/M14 INOX 0,35
				0.50	22	003787	003763	8,600–15,000	20,000	POS KBG 10013/M14 INOX 0,50
115	15	26	M14x2	0.35	22	220825	955260	6,000–12,500	15,000	POS KBG 11515/M14 INOX 0,35
				0.50	22	003824	003800	6,000–12,500	15,000	POS KBG 11515/M14 INOX 0,50
125	15	19	M14x2	0.35	28	531174	-	6,000–12,500	15,000	POS KBG 12515/M14 INOX 0,35
				0.50	28	003848	-	6,000–12,500	15,000	POS KBG 12515/M14 INOX 0,50





# Threaded bevel brushes

## knotted

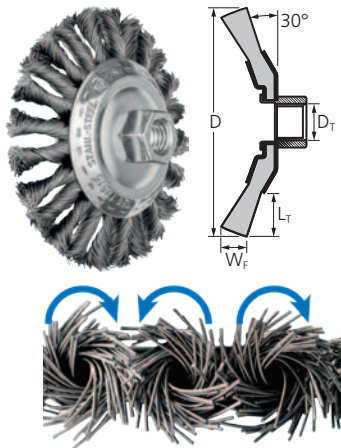

### KBG CT, COMBITWIST

Very aggressive brush. Excellent for heavy-duty brushing such as deburring, cleaning and derusting.

#### Advantages:

- Optimal access to hard-to-reach areas such as inner edges, grooves and keyways.
- Maximum economic efficiency due to the longest tool life and the highest stock removal.
- High level of comfort thanks to smooth running with no brush recoiling.
- Suitable for work on corners and edges as the knots are less likely to unravel.

#### Recommendations for use:

- For optimum results, use on powerful angle grinders.

#### Ordering notes:

- For the 5-piece packaging unit, please specify the description without "POS".

#### PFERDVALUE:

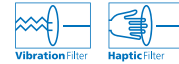

D [mm]	W <sub>f</sub> [mm]	L <sub>t</sub> [mm]	D <sub>T</sub>	D <sub>f</sub> [mm]	Knots [pcs.]	Packaging		Opt. RPM	Max. RPM	Description
						1	5			
						EAN 4007220				

#### Steel wire (ST) – COMBITWIST type

100	13	22	M14x2	0.50	22	593431	955277	10,000–15,000	20,000	POS KBG 10013/M14 CT ST 0,50
115	15	26	M14x2	0.50	22	593448	955284	7,500–12,500	15,000	POS KBG 11515/M14 CT ST 0,50
125	15	19	M14x2	0.50	28	593455	-	7,500–12,500	15,000	POS KBG 12515/M14 CT ST 0,50

#### Stainless steel wire (INOX) – COMBITWIST type

All INOX brushes are degreased.

100	13	22	M14x2	0.35	22	593462	955291	8,000–15,000	20,000	POS KBG 10013/M14 CT INOX 0,35
				0.50	22	003794	003770	8,000–15,000	20,000	POS KBG 10013/M14 CT INOX 0,50
115	15	26	M14x2	0.35	22	593479	955307	6,000–12,500	15,000	POS KBG 11515/M14 CT INOX 0,35
				0.50	22	003831	003817	6,000–12,500	15,000	POS KBG 11515/M14 CT INOX 0,50
125	15	19	M14x2	0.35	28	593486	-	6,000–12,500	15,000	POS KBG 12515/M14 CT INOX 0,35
				0.50	28	003855	-	6,000–12,500	15,000	POS KBG 12515/M14 CT INOX 0,50



### RBU, for angle grinders

Suitable for medium-duty brushing such as derusting, cleaning of weld seams and light deburring work.



#### Advantages:

- Suitable for use on angle grinders up to 80 m/s.
- Highly flexible, enabling optimal adjustment to the workpiece contour.
- Creates fine surfaces.

#### Recommendations for use:

- For optimum results, use on speed-adjustable angle grinders.

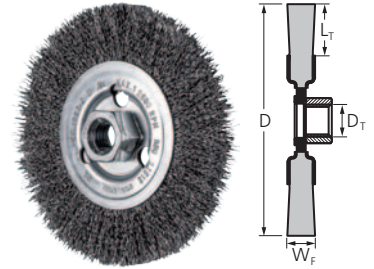

D [mm]	W <sub>F</sub> [mm]	L <sub>T</sub> [mm]	D <sub>T</sub>	D <sub>F</sub> [mm]	Packaging	Opt. RPM	Max. RPM	Description
								
					<b>EAN 4007220</b>			

#### Steel wire (ST)

115	12	25	M14x2	0.30	806968	6,300–12,500	12,500	POS RBU 11512/M14 ST 0,30
125	12	15	M14x2	0.30	806975	5,500–11,000	11,000	POS RBU 12512/M14 ST 0,30

#### Stainless steel wire (INOX)

All INOX brushes are degreased.

115	12	25	M14x2	0.30	806982	5,000–12,500	12,500	POS RBU 11512/M14 INOX 0,30
125	12	15	M14x2	0.30	806999	4,400–11,000	11,000	POS RBU 12512/M14 INOX 0,30

### RBU, POLISCRATCH

Excellent for processing and removing soft materials such as underseal and anti-drumming compound. Ideally suited to achieving rough, like sandblasted, surfaces due to the specific geometry of the filament material.



#### Recommendations for use:

- Use only on speed-adjustable angle and straight grinders.
- Can be resharpened up to 10x. To do so, press the wire tips onto a sharpening block for around 2–3 seconds. Change the running direction to sharpen the tool.

#### PFERDVALUE:



#### Advantages:

- High cooling effect and no smearing or loading of the brush due to the open construction of the filament material.
- Longer tool life as the brush can be resharpened using a sharpening block.

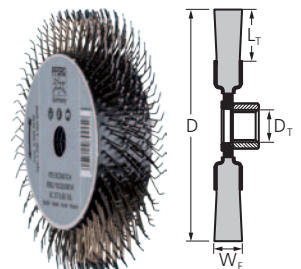

D [mm]	W <sub>F</sub> [mm]	L <sub>T</sub> [mm]	D <sub>T</sub>	D <sub>F</sub> [mm]	Packaging	Opt. RPM	Max. RPM	Description
					5x 			
					<b>EAN 4007220</b>			

#### Steel wire (ST)

100	20	18	M14x2	0.60	892459	1,200–3,500	6,000	POS RBU 10020/M14 SC ST 0,60
-----	----	----	-------	------	--------	-------------	-------	------------------------------



**Arbor BO 8/M14**  
(EAN 4007220900482)

**Safety note:** Exclusively for use with POLISCRATCH brushes.

#### For more information:

Detailed information on accessories can be found on pages 55 and 56.



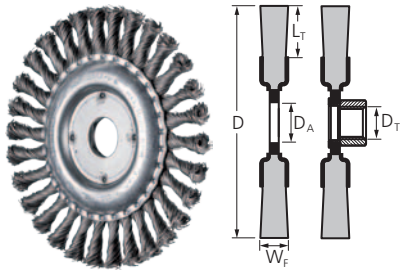

### RBG

Aggressive brush. Suitable for heavy-duty brushing in metalwork such as descaling, derusting, deburring, cleaning of weld seams and removal of adhesive residues.

#### Advantages:

- Aggressive brushing effect due to the very stiff wire knots.

#### Recommendations for use:

- For optimum results, use on powerful angle grinders.

#### Ordering notes:

- For the 10-piece packaging unit, please specify the description without "POS".

D [mm]	W <sub>F</sub> [mm]	L <sub>T</sub> [mm]	D <sub>A</sub> / D <sub>T</sub>	D <sub>F</sub> [mm]	Knots [pcs.]	Packaging		Opt. RPM	Max. RPM	Description
						1	10			
						EAN 4007220				

#### Steel wire (ST)

100	12	28	M14x2	0.50	22	658970	-	10,000–15,000	20,000	POS RBG 10012/M14 ST 0,50
115	12	22	22.2	0.50	24	153512	954966	6,300–12,500	12,500	POS RBG 11512/22,2 ST 0,50
			M14x2	0.50	24	658987	-	6,300–12,500	12,500	POS RBG 11512/M14 ST 0,50
125	12	28	22.2	0.50	24	530597	952702	5,500–12,500	12,500	POS RBG 12512/22,2 ST 0,50
			M14x2	0.50	24	658994	-	5,500–12,500	12,500	POS RBG 12512/M14 ST 0,50
150	13	26	22.2	0.60	30	597996	-	5,000–10,000	10,000	POS RBG 15013/22,2 ST 0,60
178	13	38	22.2	0.50	30	153413	954973	4,500–8,500	9,000	POS RBG 17813/22,2 ST 0,50
			M14x2	0.50	30	659007	-	4,500–8,500	9,000	POS RBG 17813/M14 ST 0,50
			22.2	0.80	30	578940	-	4,500–8,500	9,000	POS RBG 17813/22,2 ST 0,80

#### Stainless steel wire (INOX)

All INOX brushes are degreased.

115	12	22	22.2	0.35	24	220795	954980	5,000–12,500	12,500	POS RBG 11512/22,2 INOX 0,35
			22.2	0.50	24	003732	003459	5,000–12,500	12,500	POS RBG 11512/22,2 INOX 0,50
			M14x2	0.35	24	659014	-	5,000–12,500	12,500	POS RBG 11512/M14 INOX 0,35
			M14x2	0.50	24	003749	-	5,000–12,500	12,500	POS RBG 11512/M14 INOX 0,50
125	12	28	22.2	0.35	24	530788	954997	4,400–12,500	12,500	POS RBG 12512/22,2 INOX 0,35
			22.2	0.50	24	003510	003565	4,400–12,500	12,500	POS RBG 12512/22,2 INOX 0,50
			M14x2	0.35	24	659021	-	4,400–12,500	12,500	POS RBG 12512/M14 INOX 0,35
			M14x2	0.50	24	003527	-	4,400–12,500	12,500	POS RBG 12512/M14 INOX 0,50
178	13	38	22.2	0.35	30	220733	955000	3,600–8,500	9,000	POS RBG 17813/22,2 INOX 0,35
			22.2	0.50	30	003619	003657	3,600–8,500	9,000	POS RBG 17813/22,2 INOX 0,50
			M14x2	0.35	30	659038	-	3,600–8,500	9,000	POS RBG 17813/M14 INOX 0,35
			M14x2	0.50	30	003626	-	3,600–8,500	9,000	POS RBG 17813/M14 INOX 0,50

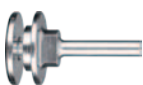

#### Arbor BO 8/22,2 100-125 (EAN 4007220751930):

For knotted wheel brushes up to a diameter of 125 mm with a D<sub>A</sub> of 22.2 mm.



#### BO 12/22,2 150-180 (EAN 4007220107850):

For knotted and crimped wheel brushes with a diameter of 150–180 mm and a D<sub>A</sub> of 22.2 mm.

#### For more information:

Detailed information on accessories can be found on pages 55 and 56.



## RBG CT, COMBITWIST

Very aggressive brush. Suitable for heavy-duty brushing in metalwork such as descaling, derusting, deburring, cleaning of weld seams and removal of adhesive residues.



### Advantages:

- Maximum economic efficiency due to the longest tool life and the highest stock removal.
- High level of comfort thanks to smooth running with no brush recoiling.
- Suitable for work on corners and edges as the knots are less likely to unravel.

### Recommendations for use:

- For optimum results, use on powerful angle grinders.

### Ordering notes:

- For the 10-piece packaging unit, please specify the description without "POS".

### PFERDVALUE:

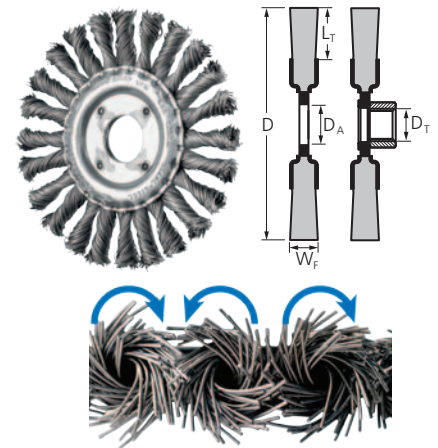
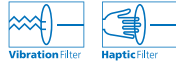

D [mm]	W <sub>F</sub> [mm]	L <sub>T</sub> [mm]	D <sub>A</sub> / D <sub>T</sub>	D <sub>F</sub> [mm]	Knots [pcs.]	Packaging		Opt. RPM	Max. RPM	Description
						EAN 4007220				

### Steel wire (ST) – COMBITWIST type

115	12	22	22.2	0.50	24	593356	955017	6,300–12,500	12,500	POS RBG 11512/22,2 CT ST 0,50
			M14x2	0.50	24	806814	-			6,300–12,500
125	12	28	22.2	0.50	24	593363	955024	5,500–12,500	12,500	POS RBG 12512/22,2 CT ST 0,50
			M14x2	0.50	24	806821	-			5,500–12,500
178	13	38	22.2	0.50	30	593370	955031	4,500–8,500	9,000	POS RBG 17813/22,2 CT ST 0,50
				0.80	30	593394	-			4,500–8,500

### Stainless steel wire (INOX) – COMBITWIST type

All INOX brushes are degreased.

115	12	22	22.2	0.35	24	593400	955048	5,000–12,500	12,500	POS RBG 11512/22,2 CT INOX 0,35		
			22.2	0.50	24	003756	003480			5,000–12,500	12,500	POS RBG 11512/22,2 CT INOX 0,50
			M14x2	0.35	24	806838	-			5,000–12,500	12,500	POS RBG 11512/M14 CT INOX 0,35
			M14x2	0.50	24	003466	-			5,000–12,500	12,500	POS RBG 11512/M14 CT INOX 0,50
125	12	28	22.2	0.35	24	593417	955055	4,400–12,500	12,500	POS RBG 12512/22,2 CT INOX 0,35		
			22.2	0.50	24	003541	003602			4,400–12,500	12,500	POS RBG 12512/22,2 CT INOX 0,50
			M14x2	0.35	24	806845	-			4,400–12,500	12,500	POS RBG 12512/M14 CT INOX 0,35
			M14x2	0.50	24	003572	-			4,400–12,500	12,500	POS RBG 12512/22,2 CT INOX 0,35
178	13	38	22.2	0.35	30	593424	955062	3,600–8,500	9,000	POS RBG 17813/22,2 CT INOX 0,35		
				0.50	30	003633	003664			3,600–8,500	9,000	POS RBG 17813/22,2 CT INOX 0,50



**Arbor BO 8/22,2 100-125**  
(EAN 4007220751930):  
For knotted wheel brushes up to a diameter of 125 mm with a D<sub>A</sub> of 22.2 mm.



**BO 12/22,2 150-180**  
(EAN 4007220107850):  
For knotted and crimped wheel brushes with a diameter of 150–180 mm and a D<sub>A</sub> of 22.2 mm.

### For more information:

Detailed information on accessories can be found on pages 55 and 56.

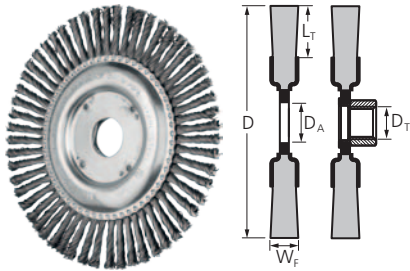

### RBG PIPE, Pipeline

Aggressive and robust brush that is able to withstand high mechanical loads. Perfect for heavy-duty brushing in pipeline and container construction.



#### Advantages:

- Extra-slim design enables optimal access to hard-to-reach areas such as root weld seams.
- Aggressive brushing effect due to the very stiff wire knots.

#### Recommendations for use:

- For optimum results, use on powerful angle grinders.

D [mm]	W <sub>F</sub> [mm]	L <sub>T</sub> [mm]	D <sub>A</sub> / D <sub>T</sub>	Knots [pcs.]	D <sub>F</sub> [mm]	Packaging	Opt. RPM	Max. RPM	Description
						 EAN 4007220			

#### Steel wire (ST)

100	6	19	16.0	32	0.50	750810	10,000–15,000	20,000	RBG 10006/16,0 PIPE ST 0,50
115	6	21	22.2	36	0.50	750926	6,300–12,500	12,500	RBG 11506/22,2 PIPE ST 0,50
			M14x2	36	0.50	750933	6,300–12,500	12,500	RBG 11506/M14 PIPE ST 0,50
125	6	18	22.2	48	0.50	750957	6,300–12,500	12,500	RBG 12506/22,2 PIPE ST 0,50
			M14x2	48	0.50	750995	6,300–12,500	12,500	RBG 12506/M14 PIPE ST 0,50
150	6	27	22.2	56	0.50	751015	5,000–10,000	10,000	RBG 15006/22,2 PIPE ST 0,50
			M14x2	56	0.50	751022	5,000–10,000	10,000	RBG 15006/M14 PIPE ST 0,50
178	6	28	22.2	56	0.50	751077	4,500–8,500	9,000	RBG 17806/22,2 PIPE ST 0,50 56Z
			M14x2	56	0.50	751084	4,500–8,500	9,000	RBG 17806/M14 PIPE ST 0,50 56Z
			22.2	76	0.50	751107	4,500–8,500	9,000	RBG 17806/22,2 PIPE ST 0,50 76Z
			M14x2	76	0.50	751114	4,500–8,500	9,000	RBG 17806/M14 PIPE ST 0,50 76Z

#### Stainless steel wire (INOX)

All INOX brushes are degreased.

100	6	19	16.0	32	0.50	751220	8,000–15,000	20,000	RBG 10006/16,0 PIPE INOX 0,50
115	6	21	22.2	36	0.50	751275	5,000–12,500	12,500	RBG 11506/22,2 PIPE INOX 0,50
			M14x2	36	0.50	751305	5,000–12,500	12,500	RBG 11506/M14 PIPE INOX 0,50
125	6	18	22.2	48	0.50	751329	5,000–12,500	12,500	RBG 12506/22,2 PIPE INOX 0,50
			M14x2	48	0.50	751343	5,000–12,500	12,500	RBG 12506/M14 PIPE INOX 0,50
150	6	27	22.2	56	0.50	751367	4,000–10,000	10,000	RBG 15006/22,2 PIPE INOX 0,50
			M14x2	56	0.50	751374	4,000–10,000	10,000	RBG 15006/M14 PIPE INOX 0,50
178	6	28	22.2	76	0.50	751398	3,600–8,500	9,000	RBG 17806/22,2 PIPE INOX 0,50 76Z
			M14x2	76	0.50	751404	3,600–8,500	9,000	RBG 17806/M14 PIPE INOX 0,50 76Z



For tools specially suited to pipeline construction, see the brochure "PFERD tools for pipeline construction".



For detailed information and ordering data on PFERD grinding wheels for pipeline construction, please refer to catalogue section 6.





### RBG PIPE CT, Pipeline COMBITWIST

Very aggressive and robust brush that is able to withstand high mechanical loads. Perfect for heavy-duty brushing in pipeline and container construction.

#### Advantages:

- Extra-slim design enables optimal access to hard-to-reach areas such as root weld seams.
- Maximum economic efficiency due to the longest tool life and the highest stock removal.
- High level of comfort thanks to smooth running with no brush recoiling.

- Suitable for work on corners and edges as the knots are less likely to unravel.

#### Recommendations for use:

- For optimum results, use on powerful angle grinders.

#### PFERDVALUE:

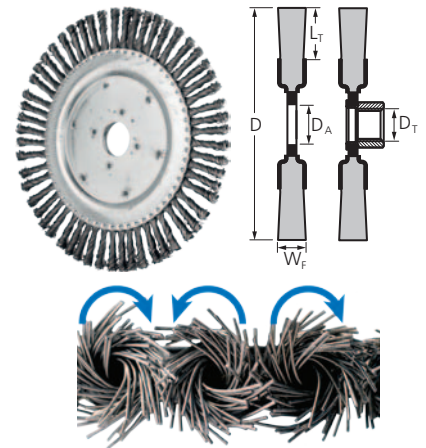
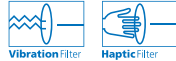

D [mm]	W <sub>F</sub> [mm]	L <sub>T</sub> [mm]	D <sub>A</sub> / D <sub>T</sub>	Knots [pcs.]	D <sub>F</sub> [mm]	Packaging	Opt. RPM	Max. RPM	Description
						 EAN 4007220			

#### Steel wire (ST) – COMBITWIST type

125	6	18	22.2	48	0.50	107799	6,300–12,500	12,500	RBG 12506/22,2 PIPE CT ST 0,50
			M14x2	48	0.50	107805	6,300–12,500	12,500	RBG 12506/M14 PIPE CT ST 0,50
178	6	28	22.2	72	0.50	751190	4,500–8,500	9,000	RBG 17806/22,2 PIPE CT ST 0,50 72Z
			M14x2	72	0.50	751206	4,500–8,500	9,000	RBG 17806/M14 PIPE CT ST 0,50 72Z

## Wheel brushes, knotted

### RBG, stationary

Aggressive and robust brush that is able to withstand high mechanical loads. Suitable for all heavy-duty stationary and automated brushing, e.g. deburring work.





#### Advantages:

- Aggressive brushing effect due to the very stiff wire knots.
- Can be used with all common stationary drive systems and bench grinders thanks to the variable arbor hole diameter.

#### Ordering notes:

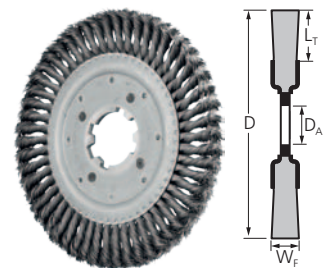
- Please complete the description with the desired filament material diameter (D<sub>F</sub>).
- Grit size DIA 270 = D 64,
- grit size DIA 400 = D 46



D [mm]	W <sub>F</sub> [mm]	L <sub>T</sub> [mm]	D <sub>A</sub> [mm]	Knots [pcs.]	D <sub>F</sub> [mm]		Opt. RPM	Max. RPM		Description
					0.35	0.50				
					EAN 4007220					

#### Steel wire (ST)

200	16	44	50.8	34	956540	956557	4,000–6,500	8,500	1	RBG 20016/50,8 ST ...
250	16	41	50.8	54	956564	956571	2,000–3,400	4,500	1	RBG 25016/50,8 ST ...

#### Stainless steel wire (INOX) Diamond (DIA)

190	30	50	22.2	24	-	107898	1,000–2,000	8,000	1	POS RBG 19030/22,2 INOX 0,50 DIA 270
					-	107911	1,000–2,000	8,000	1	POS RBG 19030/22,2 INOX 0,50 DIA 400



#### Arbor BO 12/22,2 200 (EAN 4007220107867):

For knotted and crimped wheel brushes with a diameter of 200 mm and a D<sub>A</sub> of 22.2 mm. **Note: Adapter pair**

**APM 50,8/22,2-30** (EAN 4007220900390) is required to use the product with the arbor.



#### Adapter pair APM 50,8/22,2-30 (EAN 4007220900390):

Reduces the arbor hole diameters to the required dimensions.

Suitable for knotted wheel brushes with a diameter of 200–250 mm and crimped wheel brushes designed as deburring brushes.

#### For more information:

Detailed information on accessories can be found on pages 55 and 56.



# Wheel brushes

## crimped

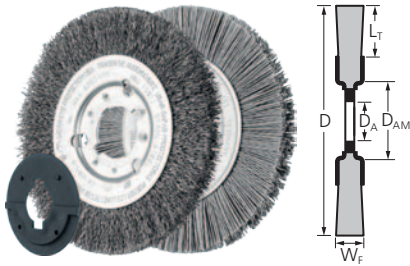

### RBU, slim

Excellent for medium-duty hand-held or automated brushing of workpieces with large surfaces.

#### Advantages:

- Can be used with all common stationary drive systems and bench grinders thanks to the variable arbor hole diameter.
- Can be packed as wide rollers without gaps because of their special design.

- Highly flexible, enabling optimal adjustment to the workpiece contour.

#### Ordering notes:

- Please order adapter set AK 32 separately.
- Wheel brushes with diameters 100 and 125 mm cannot be used with adapter set AK 32.

D [mm]	W <sub>F</sub> [mm]	L <sub>T</sub> [mm]	D <sub>A</sub> [mm]	D <sub>AM</sub> [mm]	D <sub>F</sub> [mm]	Packaging	Opt. RPM	Max. RPM	Description
						 EAN 4007220			

#### Steel wire (ST)

100	12	24	14.0	-	0.15	597866	4,000–6,000	8,000	RBU 10012/14,0 ST 0,15
					0.30	597873	4,000–6,000	8,000	RBU 10012/14,0 ST 0,30
125	12	32	14.0	-	0.30	806791	4,000–6,000	8,000	RBU 12512/14,0 ST 0,30
150	12	28	22.2	31.8	0.25	530412	3,000–4,500	6,000	RBU 15012/22,2 ST 0,25
180	12	43	22.2	31.8	0.30	658734	3,000–4,500	6,000	RBU 18012/22,2 ST 0,30
200	16	44	22.2	31.8	0.25	530436	3,000–4,500	6,000	RBU 20016/22,2 ST 0,25
250	20	70	22.2	31.8	0.25	530443	1,800–2,700	3,600	RBU 25020/22,2 ST 0,25

#### Stainless steel wire (INOX)

All INOX brushes are degreased.

125	12	32	14.0	-	0.30	806807	3,200–5,200	8,000	RBU 12512/14,0 INOX 0,30
150	12	28	22.2	31.8	0.30	597880	2,400–3,900	6,000	RBU 15012/22,2 INOX 0,30
180	12	43	22.2	31.8	0.30	658796	2,400–3,900	6,000	RBU 18012/22,2 INOX 0,30
200	16	44	22.2	31.8	0.30	597910	2,400–3,900	6,000	RBU 20016/22,2 INOX 0,30
250	20	70	22.2	31.8	0.30	597927	1,400–2,300	3,600	RBU 25020/22,2 INOX 0,30

#### Silicon carbide (SiC) plastic filament

100	12	22	12.0	-	1.00	597903	3,200–5,200	8,000	RBU 10012/12,0 SiC 80 1,00
					0.90	220870	3,200–5,200	8,000	RBU 10012/12,0 SiC 180 0,90
150	16	32	12.0	31.8	1.00	530467	2,400–3,900	8,000	RBU 15016/12,0 SiC 80 1,00
					0.90	220894	2,400–3,900	8,000	RBU 15016/12,0 SiC 180 0,90
200	16	32	22.2	31.8	1.00	530474	1,800–2,900	4,500	RBU 20016/22,2 SiC 80 1,00
					0.90	220917	1,800–2,900	4,500	RBU 20016/22,2 SiC 180 0,90
250	16	38	22.2	31.8	1.00	530481	1,400–2,300	3,600	RBU 25016/22,2 SiC 80 1,00
					0.90	220948	1,400–2,300	3,600	RBU 25016/22,2 SiC 180 0,90

#### Ceramic oxide grain (CO) plastic filament

100	12	22	12.0	-	1.10	837269	3,200–5,200	8,000	RBU 10012/12,0 CO 120 1,10
150	16	28	12.0	31.8	1.10	837276	2,400–3,900	6,000	RBU 15016/12,0 CO 120 1,10
200	16	38	22.2	31.8	1.10	837283	1,800–2,900	4,500	RBU 20016/22,2 CO 120 1,10

#### Nylon plastic filament

100	12	22	12.0	-	0.40	899298	3,200–5,200	8,000	RBU 10012/12,0 Nylon 0,40
150	16	32	12.0	31.8	0.40	899304	3,200–5,200	8,000	RBU 15016/12,0 Nylon 0,40
200	16	32	22.2	31.8	0.40	899311	2,400–3,900	6,000	RBU 20016/22,2 Nylon 0,40



#### Arbor BO 8/12-14 100-125

(EAN 4007220107843): For crimped wheel brushes with a diameter of 100–125 mm and a  $D_A / D_{AM}$  of 12 mm and 14 mm.

#### BO 12/22,2 150-180

(EAN 4007220107850): For knotted and crimped wheel brushes with a diameter of 150–180 mm and a  $D_A$  of 22.2 mm.



#### BO 12/22,2 200

(EAN 4007220107867): For knotted and crimped wheel brushes with a diameter of 200 mm and a  $D_A$  of 22.2 mm.

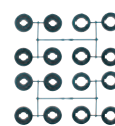

#### Adapter set AK 32

(EAN 4007220608593): Arbor hole diameters contained in the set in mm (inch): 20 / 18 / 14 / 12 / 25.4 (1) / 22.2 (7/8) / 16 (5/8) / 12.7 (1/2).

#### For more information:

Detailed information on accessories can be found on pages 55 and 56.

## RBU, slim, stationary

Its plastic filament makes this product particularly suitable for deburring complicated components such as cylinder heads or gear toothings. Ideal for processing aluminium due to the longer trim length and higher degree of flexibility. Suitable for use on stationary machines, automated centres and robots.

### Advantages:

- Can be packed as wide rollers without gaps because of their special design.
- Highly flexible, enabling optimal adjustment to the workpiece contour.

### Recommendations for use:

- Use CO as the filament material for particularly aggressive work and a high workpiece surface quality.

### Ordering notes:

- Please complete the description with the desired grit size and filament material diameter ( $D_f$ ).

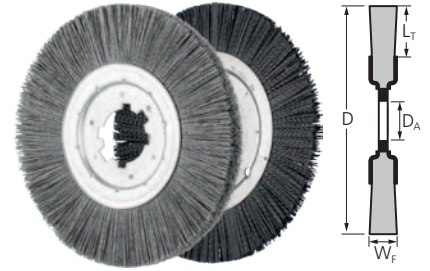

D [mm]	$W_F$ [mm]	$L_T$ [mm]	$D_A$ [mm]	Grit size / $D_f$ [mm]				Opt. RPM	Max. RPM		Description
				120 0.55	120 1.10	180 0.90	320 0.55				
				EAN 4007220							

### Silicon carbide (SiC) plastic filament

200	13	43	50.8	807248	-	807255	807262	2,400–3,900	6,000	1	RBU 20013/50,8 SiC ...
250	15	55	50.8	807279	-	807286	807293	1,400–2,300	3,600	1	RBU 25015/50,8 SiC ...

### Ceramic oxide grain (CO) plastic filament

200	13	46	50.8	-	837290	-	-	2,400–3,900	6,000	1	RBU 20013/50,8 CO ...
250	15	63	50.8	-	837306	-	-	1,400–2,300	3,600	1	RBU 25015/50,8 CO ...



### Arbor BO 12/22,2 200

(EAN 4007220107867):

For knotted and crimped wheel brushes with a diameter of 200 mm and a  $D_A$  of 22.2 mm.

### Note: Adapter pair APM 50,8/22,2-30

(EAN 4007220900390) is required to use the product with the arbor.



### Adapter pair APM 50,8/22,2-30

(EAN 4007220900390): Reduces the arbor hole diameters to the required dimensions.

Suitable for knotted wheel brushes with a diameter of 200–250 mm and crimped wheel brushes designed as deburring brushes.

### For more information:

Detailed information on accessories can be found on pages 55 and 56.

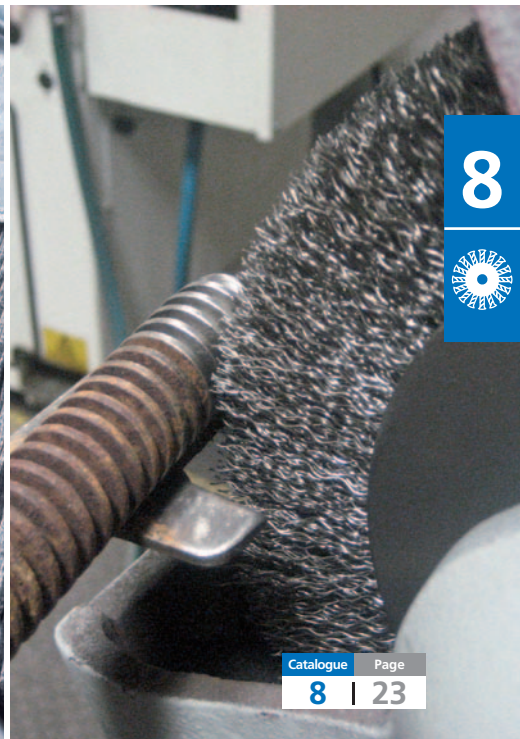

# Wheel brushes

## crimped



### RBU, wide, universal use

Excellent for medium-duty hand-held or automated brushing of workpieces with large surfaces. Developed for universal use in the workshop.

#### Advantages:

- Can be used with all common stationary drive systems and bench grinders thanks to the variable arbor hole diameter.

#### Ordering notes:

- Diameters of 150–200 mm are supplied together with adapter set AK 32-2.
- Diameters of 100–125 mm are supplied with a variable arbor hole.

D [mm]	W <sub>F</sub> [mm]	L <sub>T</sub> [mm]	D <sub>A</sub> [mm]	D <sub>AM</sub> [mm]	D <sub>F</sub> [mm]	Packaging	Opt. RPM	Max. RPM	Description	
EAN 4007220										

#### Steel wire (ST)

100	20	25	12/14/18/22.2/25.4	30.0	0.30	956236	4,000–6,000	8,000	POS RBU 10020/14,0 ST 0,30
	28	25	12/14/18/22.2/25.4	30.0	0.30	956243	4,000–6,000	8,000	POS RBU 10028/14,0 ST 0,30
125	20	30	12/14/18/22.2/25.4	30.0	0.30	956250	3,000–4,500	6,000	POS RBU 12520/14,0 ST 0,30
	28	30	12/14/18/22.2/25.4	30.0	0.30	956274	3,000–4,500	6,000	POS RBU 12528/14,0 ST 0,30
150	25	25	AK 32-2	50.8	0.20	956281	3,000–4,500	6,000	POS RBU 15025/AK32-2 ST 0,20
	25	25	AK 32-2	50.8	0.30	956304	3,000–4,500	6,000	POS RBU 15025/AK32-2 ST 0,30
	38	25	AK 32-2	50.8	0.20	956298	3,000–4,500	6,000	POS RBU 15038/AK32-2 ST 0,20
	38	25	AK 32-2	50.8	0.30	956311	3,000–4,500	6,000	POS RBU 15038/AK32-2 ST 0,30
180	25	40	AK 32-2	50.8	0.20	956335	3,000–4,500	6,000	POS RBU 18025/AK32-2 ST 0,20
	25	40	AK 32-2	50.8	0.30	956342	3,000–4,500	6,000	POS RBU 18025/AK32-2 ST 0,30
	38	40	AK 32-2	50.8	0.30	956359	3,000–4,500	6,000	POS RBU 18038/AK32-2 ST 0,30
200	25	50	AK 32-2	50.8	0.20	956366	2,300–3,400	4,500	POS RBU 20025/AK32-2 ST 0,20
	25	50	AK 32-2	50.8	0.30	956373	2,300–3,400	4,500	POS RBU 20025/AK32-2 ST 0,30
	38	50	AK 32-2	50.8	0.30	956380	2,300–3,400	4,500	POS RBU 20038/AK32-2 ST 0,30

#### Stainless steel wire (INOX)

100	20	25	12/14/18/22.2/25.4	30.0	0.30	956397	3,200–5,200	8,000	POS RBU 10020/14,0 INOX 0,30
	28	25	12/14/18/22.2/25.4	30.0	0.30	956403	3,200–5,200	8,000	POS RBU 10028/14,0 INOX 0,30
125	20	30	12/14/18/22.2/25.4	30.0	0.30	956410	2,400–3,900	6,000	POS RBU 12520/14,0 INOX 0,30
	28	30	12/14/18/22.2/25.4	30.0	0.30	956434	2,400–3,900	6,000	POS RBU 12528/14,0 INOX 0,30
150	25	25	AK 32-2	50.8	0.20	956441	2,400–3,900	6,000	POS RBU 15025/AK32-2 INOX 0,20
	25	25	AK 32-2	50.8	0.30	956465	2,400–3,900	6,000	POS RBU 15025/AK32-2 INOX 0,30
	38	25	AK 32-2	50.8	0.20	956458	2,400–3,900	6,000	POS RBU 15038/AK32-2 INOX 0,20
	38	25	AK 32-2	50.8	0.30	956472	2,400–3,900	6,000	POS RBU 15038/AK32-2 INOX 0,30
180	25	40	AK 32-2	50.8	0.20	956489	2,400–3,900	6,000	POS RBU 18025/AK32-2 INOX 0,20
	25	40	AK 32-2	50.8	0.30	956496	2,400–3,900	6,000	POS RBU 18025/AK32-2 INOX 0,30
	38	40	AK 32-2	50.8	0.30	956502	2,400–3,900	6,000	POS RBU 18038/AK32-2 INOX 0,30
200	25	50	AK 32-2	50.8	0.20	956519	1,800–2,900	4,500	POS RBU 20025/AK32-2 INOX 0,20
	25	50	AK 32-2	50.8	0.30	956526	1,800–2,900	4,500	POS RBU 20025/AK32-2 INOX 0,30
	38	50	AK 32-2	50.8	0.30	956533	1,800–2,900	4,500	POS RBU 20038/AK32-2 INOX 0,30

#### Silicon carbide (SiC) plastic filament

150	25	25	AK 32-2	50.8	0.55	069707	2,400–3,900	6,000	POS RBU 15025/AK32-2 SiC 120 0,55
					1.10	069691	2,400–3,900	6,000	POS RBU 15025/AK32-2 SiC 120 1,10
					0.55	069714	2,400–3,900	6,000	POS RBU 15025/AK32-2 SiC 320 0,55
200	25	50	AK 32-2	50.8	1.10	069721	2,400–3,900	6,000	POS RBU 20025/AK32-2 SiC 120 1,10



#### Arbor BO 8/12-14 100-125

(EAN 4007220107843):

For crimped wheel brushes with a diameter of 100–125 mm and a D<sub>A</sub> / D<sub>AM</sub> of 12 mm and 14 mm.

#### BO 12/22,2 150-180

(EAN 4007220107850):

For knotted and crimped wheel brushes with a diameter of 150–180 mm and a D<sub>A</sub> of 22.2 mm.



#### BO 12/22,2 200

(EAN 4007220107867):

For knotted and crimped wheel brushes with a diameter of 200 mm and a D<sub>A</sub> of 22.2 mm.



#### Adapter set AK 32-2

(4007220806890):

Arbor hole diameters contained in the set in mm

(inch): 31.75 / 20 / 18 / 14 / 12 / 25.4 (1) / 22.2 (7/8) / 19.2 (.750) / 16 (5/8) / 12.7 (1/2).

**Note:** Adapter pairs AM 50,8 for brushes with a D<sub>AM</sub> of 50.8 mm can be used in applications involving high levels of heat and forces.



### RBU, wide, industrial use

Excellent for medium-duty hand-held or automated brushing of workpieces with large surfaces. Developed specially for industrial use.

#### Advantages:

- Can be used with all common stationary drive systems and bench grinders thanks to the variable arbor hole diameter.
- High economic efficiency due to very long tool life.

#### Ordering notes:

- Diameters of 150–250 mm are supplied together with adapter set AK 32-2.
- The 100 mm diameter is supplied with a variable arbor hole.

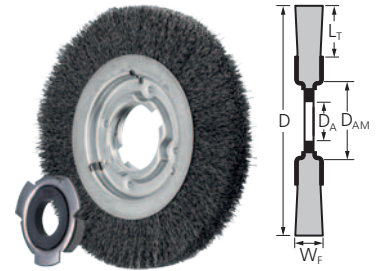

D [mm]	W <sub>F</sub> [mm]	L <sub>T</sub> [mm]	D <sub>A</sub> [mm]	D <sub>AM</sub> [mm]	D <sub>F</sub> [mm]	Packaging	Opt. RPM	Max. RPM	Description
						 EAN 4007220			

#### Steel wire (ST)

100	20	24	14.0/18.0/22.2	25.4	0.30	658710	4,000–6,000	8,000	RBU 10020/14,0 ST 0,30
	28	24	14.0/18.0/22.2	25.4	0.30	153604	4,000–6,000	8,000	RBU 10028/14,0 ST 0,30
150	25	25	AK 32-2	50.8	0.30	658727	3,000–4,500	6,000	RBU 15025/AK32-2 ST 0,30
	38	25	AK 32-2	50.8	0.30	153628	3,000–4,500	6,000	RBU 15038/AK32-2 ST 0,30
180	25	40	AK 32-2	50.8	0.30	658741	3,000–4,500	6,000	RBU 18025/AK32-2 ST 0,30
200	25	38	AK 32-2	50.8	0.30	658765	2,300–3,400	4,500	RBU 20025/AK32-2 ST 0,30
	38	38	AK 32-2	50.8	0.30	153635	2,300–3,400	4,500	RBU 20038/AK32-2 ST 0,30
250	30	50	AK 32-2	50.8	0.30	658772	1,800–2,700	3,600	RBU 25030/AK32-2 ST 0,30
	48	50	AK 32-2	50.8	0.30	220924	1,800–2,700	3,600	RBU 25048/AK32-2 ST 0,30
300	40	40	50.8	117.5	0.30	616086	1,500–2,500	3,000	RBU 30040/50,8 ST 0,30

#### Stainless steel wire (INOX)

All INOX brushes are degreased.

150	25	25	AK 32-2	50.8	0.30	658789	2,400–3,900	6,000	RBU 15025/AK32-2 INOX 0,30
	38	25	AK 32-2	50.8	0.30	220887	2,400–3,900	6,000	RBU 15038/AK32-2 INOX 0,30
180	25	40	AK 32-2	50.8	0.30	658871	2,400–3,900	6,000	RBU 18025/AK32-2 INOX 0,30
200	25	38	AK 32-2	50.8	0.30	658895	1,800–2,900	4,500	RBU 20025/AK32-2 INOX 0,30
	38	38	AK 32-2	50.8	0.30	220900	1,800–2,900	4,500	RBU 20038/AK32-2 INOX 0,30
250	30	50	AK 32-2	50.8	0.30	658901	1,400–2,300	3,600	RBU 25030/AK32-2 INOX 0,30
	48	50	AK 32-2	50.8	0.30	220931	1,400–2,300	3,600	RBU 25048/AK32-2 INOX 0,30



**Arbor BO 8/12-14 100-125**  
(EAN 4007220107843):  
For crimped wheel brushes with a diameter of 100–125 mm and a D<sub>A</sub> / D<sub>AM</sub> of 12 mm and 14 mm.



**BO 12/22,2 200**  
(EAN 4007220107867):  
For knotted and crimped wheel brushes with a diameter of 200 mm and a D<sub>A</sub> of 22.2 mm.



**Adapter set AK 32-2**  
(4007220806890):  
Arbor hole diameters contained in the set in mm (inch): 31.75 / 20 / 18 / 14 / 12 / 25.4 (1) / 22.2 (7/8) / 19.2 (.750) / 16 (5/8) / 12.7 (1/2).



**BO 12/22,2 150-180**  
(EAN 4007220107850):  
For knotted and crimped wheel brushes with a diameter of 150–180 mm and a D<sub>A</sub> of 22.2 mm.

**Note: Adapter pairs AM 50,8** for brushes with a D<sub>AM</sub> of 50.8 mm can be used in applications involving high levels of heat and forces.



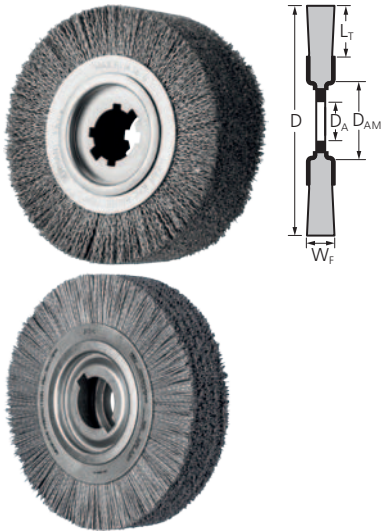

### RBU, deburring brushes

Particularly suitable for deburring pipes, cut edges and small parts on stationary machines.

The special wire construction with cord wire filament (LIT) is particularly suitable for heavy-duty brushing and aggressive brushing.



#### Advantages:

- Individual check for imbalance guarantees smooth running.
- Longest tool life thanks to high filament density.

#### Ordering notes:

- Please complete the description with the desired filament material diameter ( $D_f$ ).
- Please order adapter pairs APM 50,8 separately.

D [mm]	W <sub>F</sub> [mm]	L <sub>T</sub> [mm]	D <sub>A</sub> [mm]	D <sub>AM</sub> [mm]	D <sub>f</sub> [mm]				Opt. RPM	Max. RPM	IP	Description
					0.20	0.35	0.50	1.10				
					EAN 4007220							

#### Steel wire (ST)

LIT ST = stranded, brass-plated steel wire

250	60	50	50.8	100.0	807040	807057	807064	-	1,800–2,700	3,600	1	RBU 25060/50,8 ST ...
	60	50	50.8	100.0	-	807118	-	-	1,800–2,700	3,600	1	RBU 25060/50,8 LIT ST ...
	80	50	50.8	100.0	-	807071	-	-	1,800–2,700	3,600	1	RBU 25080/50,8 ST ...
	80	50	50.8	100.0	-	807125	-	-	1,800–2,700	3,600	1	RBU 25080/50,8 LIT ST ...
	100	50	50.8	100.0	-	807095	807101	-	1,800–2,700	3,600	1	RBU 250100/50,8 ST ...

#### Stainless steel wire (INOX)

LIT INOX = stranded INOX wire

250	60	50	50.8	100.0	807132	807149	807156	-	1,400–2,300	3,600	1	RBU 25060/50,8 INOX ...
	60	50	50.8	100.0	-	807200	-	-	1,400–2,300	3,600	1	RBU 25060/50,8 LIT INOX ...
	100	50	50.8	100.0	-	807187	807194	-	1,400–2,300	3,600	1	RBU 250100/50,8 INOX ...

#### Silicon carbide (SiC) plastic filament

250	60	45	50.8	100.0	-	-	-	069738	1,400–2,300	3,600	1	RBU 25060/50,8 SiC 120 ...
-----	----	----	------	-------	---	---	---	--------	-------------	-------	---	----------------------------



#### Adapter pair APM 50,8/22,2-30 (EAN 4007220900390):

Reduces the arbor hole diameters to the required dimensions.

Suitable for knotted wheel brushes with a diameter of 200–250 mm and crimped wheel brushes designed as deburring brushes.

#### For more information:

Detailed information on accessories can be found on pages 55 and 56.

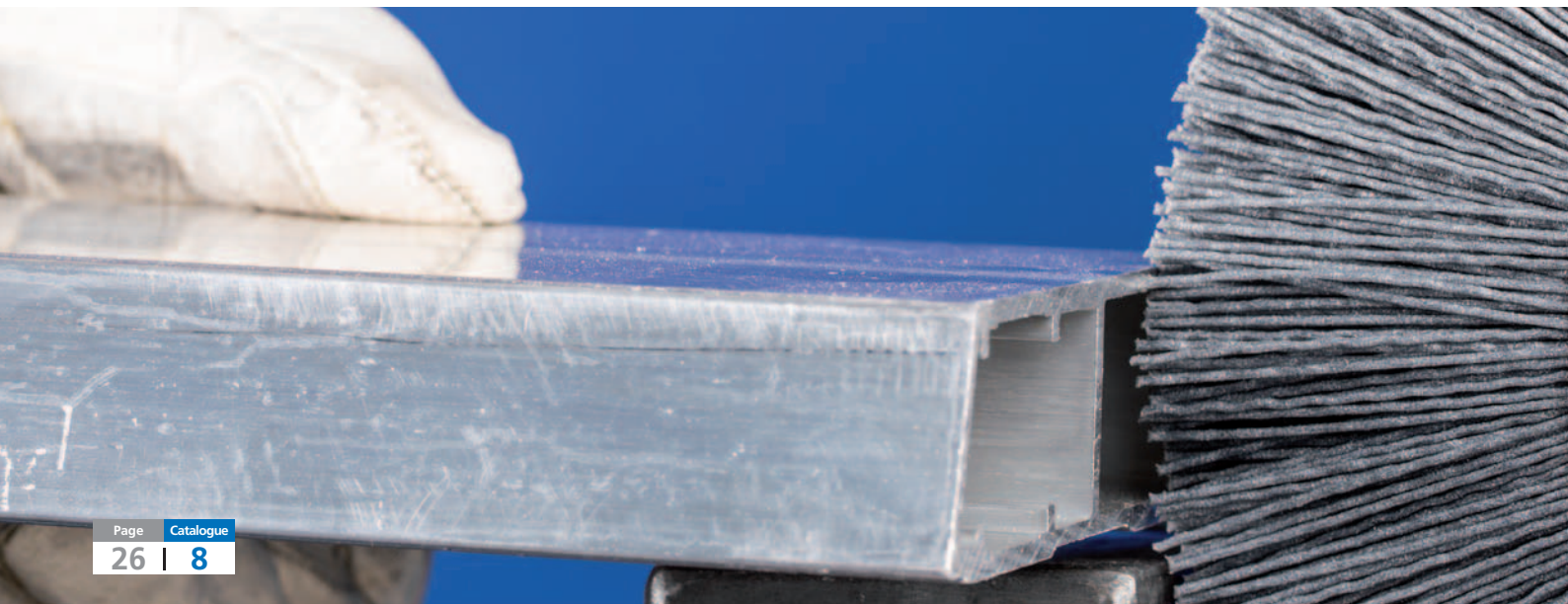

Composite brushes from PFERD have been specifically developed for industrial, automated use. They are suitable for a variety of applications and their variable clamping options mean that they can be used on many different drive systems. This offers the advantage that the workpiece can be produced and finished on the same machine. As a result, labour-intensive, manual work is reduced and reproducible results are achieved with short cycle times.

The standard type of composite brushes is suitable for tasks requiring aggressive brushing behaviour. The FLEX type is more flexible than the standard type due to its longer trim length on wheel brushes and the special arrangement of the filament on composite disc brushes, and it is particularly well suited to work on irregular surfaces.

For efficient use, numerous application parameters such as the processing time and feed rate must be coordinated with each other and the suitable brush must be selected. PFERD offers a wide range of products for the various applications. Our experienced sales representatives and technical advisers will be happy to help or visit you. Our worldwide sales addresses can be found at: [www.pferd.com](http://www.pferd.com)



## Wheel brushes, crimped

### RBUP

Particularly aggressive brush. Its plastic filament makes this product particularly suitable for deburring complicated components such as cylinder heads or gear toothing. Developed specially for industrial use.

#### Advantages:

- Long tool life and aggressive brushing effect due to a very high filament density.
- Extremely smooth operation due to even distribution of the filament material.

#### Recommendations for use:

- Use CO as the filament material for particularly aggressive work and a high workpiece surface quality.
- Select the REC type (rectangular filament) for aggressive work with SiC as the filament material.

#### Ordering notes:

- Please complete the description with the desired grit size and filament material diameter ( $D_F$ ).
- Please order adapter pairs APM 50,8 separately.

#### PFERDVALUE:



D [mm]	W <sub>F</sub> [mm]	L <sub>T</sub> [mm]	D <sub>A</sub> [mm]	Grit size / D <sub>F</sub> [mm]					Opt. RPM	Max. RPM	IP	Description
				80 1.10	80 1.14	120 0.55	120 1.10	320 0.55				
EAN 4007220												

#### Silicon carbide (SiC) plastic filament

150	25	32	50.8	-	956588	-	-	-	900-1,500	3,600	1	RBUP 15025/50,8 REC SiC ...
				956618	-	956649	956670	900-1,500	3,600	1	RBUP 15025/50,8 SiC ...	
200	25	32	50.8	-	956595	-	-	-	900-1,500	3,600	1	RBUP 20025/50,8 REC SiC ...
				956625	-	956656	956687	900-1,500	3,600	1	RBUP 20025/50,8 SiC ...	
250	25	38	50.8	-	956601	-	-	-	900-1,500	3,600	1	RBUP 25025/50,8 REC SiC ...
				956632	-	039175	956663	956694	900-1,500	3,600	1	RBUP 25025/50,8 SiC ...

#### Ceramic oxide grain (CO) plastic filament

150	25	32	50.8	956700	-	-	-	-	900-1,500	3,600	1	RBUP 15025/50,8 CO ...
200	25	32	50.8	956717	-	-	-	-	900-1,500	3,600	1	RBUP 20025/50,8 CO ...
250	25	38	50.8	956724	-	-	-	-	900-1,500	3,600	1	RBUP 25025/50,8 CO ...



**Arbor BO 12/22,2 150-180**  
(EAN 4007220107850): For knotted and crimped wheel brushes with a diameter of 150-180 mm and a  $D_A$  of 22.2 mm.



**BO 12/22,2 200**  
(EAN 4007220107867): For knotted and crimped wheel brushes with a diameter of 200 mm and a  $D_A$  of 22.2 mm.

**Note: Adapter pair AM 50,8/22,2**  
(EAN 4007220806906) is required to use the product with arbors.



**Adapter pair AM 50,8/22,2**  
(EAN 4007220806906): Reduces the arbor hole diameters to the required dimensions. Suitable for wheel brushes with a brush diameter as from 150 mm in the wide and composite types.

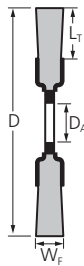

### RBUP, FLEX

Particularly flexible brush. Its plastic filament makes this product particularly suitable for deburring complicated components such as cylinder heads or gear toothing. Developed specially for industrial use.

#### Advantages:

- Long tool life and aggressive brushing effect due to a very high filament density.
- Extremely smooth operation due to even distribution of the filament material.
- Highly flexible, enabling optimal adjustment to the workpiece contour and less heat build-up.

#### Recommendations for use:

- Use CO as the filament material for particularly aggressive work and a high workpiece surface quality.
- Select the REC type (rectangular filament) for aggressive work with SiC as the filament material.

#### Ordering notes:

- Please complete the description with the desired grit size and filament material diameter ( $D_f$ ).
- Packaging unit: 1 piece

#### PFERDVALUE:



D [mm]	W <sub>F</sub> [mm]	L <sub>T</sub> [mm]	D <sub>A</sub> [mm]	Keyway [mm]	Grit size / D <sub>F</sub> [mm]					Opt. RPM	Max. RPM	Description
					80 1.10	80 1.14	120 1.10	180 0.90	320 0.55			
EAN 4007220												

#### Silicon carbide (SiC) plastic filament – FLEX type

200	25	57	50.8	-	-	039298	-	-	-	900–1,500	3,600	RBUP 20025/50,8 REC SiC...FLEX		
					038840	-	039151	-	038895			900–1,500	3,600	RBUP 20025/50,8 SiC ... FLEX
250	25	83	50.8	-	-	038505	-	-	-	900–1,500	3,600	RBUP 25025/50,8 REC SiC...FLEX		
		83	50.8	-	038499	-	038871	-	039168			900–1,500	3,600	RBUP 25025/50,8 SiC ... FLEX
		70	50.8	6.3 x 12.7	-	-	-	038666	-			900–1,500	3,600	RBUP 25025/50,8 SiC ... FLEX
300	25	60	50.8	6.3 x 12.7	038772	-	038765	038741	-	500–800	1,800	RBUP 30025/50,8 SiC ... FLEX		
350	25	89	50.8	6.3 x 12.7	038710	-	-	038680	-	500–800	1,800	RBUP 35025/50,8 SiC ... FLEX		

#### Ceramic oxide grain (CO) plastic filament – FLEX type

300	25	60	50.8	6.3 x 12.7	038796	-	038802	-	-	500–800	1,800	RBUP 30025/50,8 CO ... FLEX
350	25	89	50.8	6.3 x 12.7	038826	-	038819	-	-	500–800	1,800	RBUP 35025/50,8 CO ... FLEX



#### BO 12/22,2 200

(EAN 4007220107867):

For knotted and crimped wheel brushes with a diameter of 200 mm and a  $D_A$  of 22.2 mm.

**Note:** Adapter pair AM 50,8/22,2 (EAN 4007220806906) is required to use the product with arbors.



#### Adapter pair AM 50,8/22,2

(EAN 4007220806906):

Reduces the arbor hole diameters to the required dimensions. Suitable for wheel brushes with a brush diameter as from 150 mm in the wide and composite versions.

#### For more information:

Detailed information on accessories can be found on pages 55 and 56.





### DBUR, with bridle

Particularly aggressive brush. Particularly suitable for deburring and work on surfaces on stationary machines.

#### Advantages:

- Long tool life and aggressive brushing effect due to a very high filament density.
- Extremely smooth operation due to even distribution of the filament material.

#### Recommendations for use:

- Use CO as the filament material for particularly aggressive work and a high workpiece surface quality.
- Select the REC type (rectangular filament) for aggressive work with SiC as the filament material.
- Remove the bridle once the filament is worn down. Then the rest of the filament can be used.
- Remove the bridle before starting work if you would like to achieve a large spreading diameter or access hard-to-reach areas.

- Brushes with a diameter of 75 mm with an M14 thread are suitable for use on speed-adjustable angle grinders.

#### Ordering notes:

- Please complete the description with the desired grit size and filament material diameter ( $D_f$ ).
- All composite disc brushes with a 22.2 mm diameter arbor hole are supplied with two drive pin holes with 6.5 mm diameter. Pitch circle diameter of 31 mm.

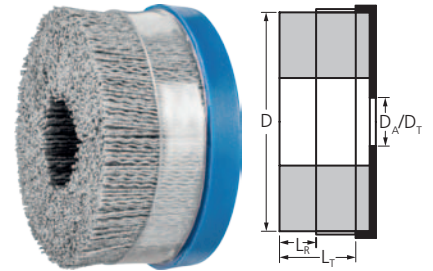

#### PFERDVALUE:



D [mm]	L <sub>R</sub> [mm]	L <sub>T</sub> [mm]	D <sub>A</sub> / D <sub>T</sub>	Grit size / D <sub>f</sub> [mm]					Opt. RPM	Max. RPM	IP	Description
				80 1.10	80 1.14	120 0.55	120 1.10	320 0.55				
EAN 4007220												

#### Silicon carbide (SiC) plastic filament

75	19	38	22.2	-	032787	-	-	-	2,400–3,900	4,500	1	DBUR 75/22,2 REC SiC ...	
				22.2	032794	-	033517	033500	033524	2,400–3,900	4,500	1	DBUR 75/22,2 SiC ...
				M14x2	-	899373	-	-	-	2,400–3,900	6,000	1	DBUR 75/M14 REC SiC ...
				M14x2	899380	-	-	-	-	2,400–3,900	6,000	1	DBUR 75/M14 SiC ...
100	19	38	22.2	-	808740	-	-	-	1,400–2,300	3,500	1	DBUR 100/22,2 REC SiC ...	
				808757	-	-	808764	808771	1,400–2,300	3,500	1	DBUR 100/22,2 SiC ...	
125	19	38	22.2	-	808795	-	-	-	1,200–2,000	3,000	1	DBUR 125/22,2 REC SiC ...	
				808788	-	-	808801	808818	1,200–2,000	3,000	1	DBUR 125/22,2 SiC ...	
150	19	38	22.2	808849	-	-	808856	808863	1,000–1,600	2,500	1	DBUR 150/22,2 SiC ...	
				-	808825	-	-	-	1,000–1,600	2,500	1	DBUR 150/22,2 REC SiC ...	

#### Ceramic oxide grain (CO) plastic filament

75	19	38	22.2	-	-	-	033593	-	2,400–3,900	4,500	1	DBUR 75/22,2 CO ...
100	19	38	22.2	-	-	-	837221	-	1,400–2,300	3,500	1	DBUR 100/22,2 CO ...
125	19	38	22.2	-	-	-	837245	-	1,200–2,000	3,000	1	DBUR 125/22,2 CO ...
150	19	38	22.2	-	-	-	837252	-	1,000–1,600	2,500	1	DBUR 150/22,2 CO ...



#### Arbor BO 12/22,2 75-100

(EAN 4007220808887):

For all composite disc brushes with a diameter of 75–100 mm and a  $D_A$  of 22.2 mm.

#### BO 12/22,2 125-150

(EAN 4007220808894):

For all composite disc brushes with a diameter of 125–150 mm and a  $D_A$  of 22.2 mm.

#### For more information:

Detailed information on accessories can be found on pages 55 and 56.



More PFERD tools and a large number of recommendations for use when working with aluminium can be found in our PRAXIS brochure, "PFERD tools for use on aluminium". Please contact us.





# Composite

## Composite disc brushes, crimped

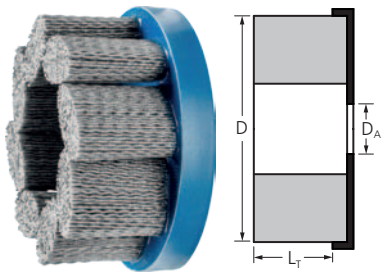

### DBU, FLEX

Particularly flexible brush. Particularly suitable for deburring and work on surfaces on stationary machines.

#### Advantages:

- Long tool life and aggressive brushing effect due to a very high filament density.
- Extremely smooth operation due to even distribution of the filament material.
- Special arrangement of the filament enables optimal adjustment to the workpiece contour and less heat build-up.
- Select the REC type (rectangular filament) for aggressive work with SiC as the filament material.

#### Ordering notes:

- Please complete the description with the desired grit size and filament material diameter ( $D_f$ ).
- All composite disc brushes with a 22.2 mm diameter arbor hole are supplied with two drive pin holes with 6.5 mm diameter. Pitch circle diameter of 31 mm.

#### PFERDVALUE:



D [mm]	L <sub>T</sub> [mm]	D <sub>A</sub> [mm]	Grit size / D <sub>f</sub> [mm]				Opt. RPM	Max. RPM	IP	Description
			80 1.10	80 1.14	120 1.10	320 0.55				
EAN 4007220										

#### Silicon carbide (SiC) plastic filament – FLEX type

75	38	22.2	-	033647	-	-	2,400–3,900	4,500	1	DBU 75/22,2 REC SiC ... FLEX
			033678	-	033685	033708	2,400–3,900	4,500	1	DBU 75/22,2 SiC ... FLEX
100	38	22.2	-	033715	-	-	1,400–2,300	3,500	1	DBU 100/22,2 REC SiC ... FLEX
			033739	-	033746	033760	1,400–2,300	3,500	1	DBU 100/22,2 SiC ... FLEX
150	38	22.2	-	033777	-	-	1,000–1,600	2,500	1	DBU 150/22,2 REC SiC ... FLEX
			033791	-	033807	033821	1,000–1,600	2,500	1	DBU 150/22,2 SiC ... FLEX

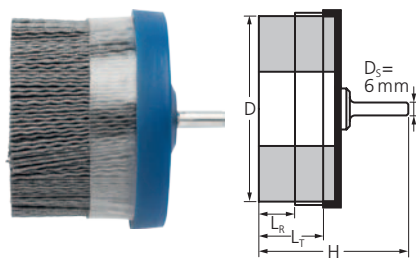

### DBUR, shank-mounted, with bridle

Particularly aggressive brush. Particularly suitable for deburring and work on surfaces on stationary machines.

#### Advantages:

- Long tool life and aggressive brushing effect due to a very high filament density.
- Extremely smooth operation due to even distribution of the filament material.

#### Recommendations for use:

- Use CO as the filament material for particularly aggressive work and a high workpiece surface quality.
- Remove the bridle once the filament is worn down. Then the rest of the filament can be used.

- Remove the bridle before starting work if you would like to achieve a large spreading diameter or access hard-to-reach areas.

#### Ordering notes:

- Please complete the description with the desired filament material diameter ( $D_f$ ).

#### PFERDVALUE:



D [mm]	L <sub>R</sub> [mm]	L <sub>T</sub> [mm]	H [mm]	Grit size / D <sub>f</sub> [mm]			Opt. RPM	Max. RPM	IP	Description
				120 0.55	120 1.00	120 1.10				
EAN 4007220										

#### Silicon carbide (SiC) plastic filament

50	19	38	80	101582	104262	-	1,500–3,500	5,000	1	DBUR 50/6 SiC 120 ...
63	19	38	80	104675	104682	-	1,500–3,500	5,000	1	DBUR 63/6 SiC 120 ...

#### Ceramic oxide grain (CO) plastic filament

50	19	38	80	-	-	104699	1,500–3,500	5,000	1	DBUR 50/6 CO 120 ...
63	19	38	80	-	-	104705	1,500–3,500	5,000	1	DBUR 63/6 CO 120 ...

**Arbor BO 12/22,2 75-100**  
(EAN 4007220808887):  
For all composite disc brushes with a diameter of 75–100 mm and a  $D_A$  of 22.2 mm.

**BO 12/22,2 125-150**  
(EAN 4007220808894):  
For all composite disc brushes with a diameter of 125–150 mm and a  $D_A$  of 22.2 mm.

#### For more information:

Detailed information on accessories can be found on pages 55 and 56.

### PBUPR, with bridle

Particularly suitable for deburring and work on surfaces on stationary machines.

#### Advantages:

- Long tool life and aggressive brushing effect due to a very high filament density.
- Extremely smooth operation due to even distribution of the filament material.
- Optimal access to hard-to-reach areas such as drilled holes and cavities as the wires spread out upon rotation.

#### Recommendations for use:

- Use CO as the filament material for particularly aggressive work and a high workpiece surface quality.
- Remove the bridle once the filament is worn down. Then the rest of the filament can be used.
- Remove the bridle before starting work if you would like to ensure particularly flexible working, achieve a large spreading diameter or access hard-to-reach areas.

#### Ordering notes:

- Please complete the description with the desired grit size and filament material diameter ( $D_f$ ).
- All brushes are supplied with a bridle.

#### PFERDVALUE:

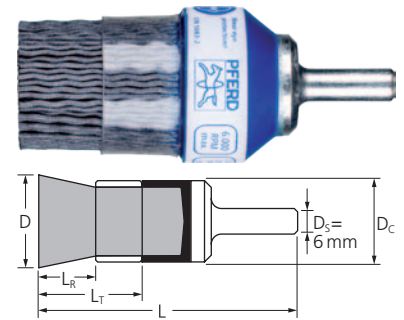

D [mm]	D <sub>C</sub> [mm]	L <sub>R</sub> [mm]	L <sub>T</sub> [mm]	L [mm]	Grit size / D <sub>f</sub> [mm]			Opt. RPM	Max. RPM	IP	Description	
					120 0.55	120 1.00	120 1.10					
					EAN 4007220							

#### Silicon carbide (SiC) plastic filament

25	28	14	28	70	070383	070369	-	2,400–3,900	6,000	1	PBUPR 2528/6 SiC ...
38	38	14	28	77	070390	070376	-	2,000–3,200	5,000	1	PBUPR 3838/6 SiC ...

#### Ceramic oxide grain (CO) plastic filament

25	28	14	28	70	-	-	104712	2,400–3,900	6,000	1	PBUPR 2528/6 CO ...
38	38	14	28	77	-	-	104729	2,000–3,200	5,000	1	PBUPR 3838/6 CO ...



# Shank mounted end brushes

## crimped

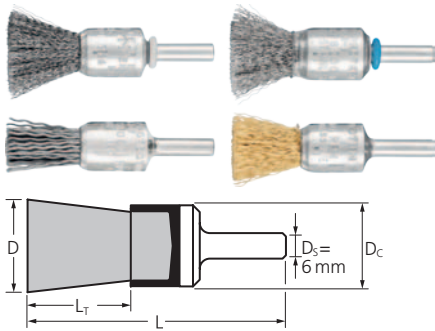

### PBU

Suitable for light brushing such as deburring, cleaning and derusting.



#### Advantages:

- Optimal access to hard-to-reach areas such as drilled holes and cavities as the wires spread out upon rotation.

#### Recommendations for use:

- For the best results, use a tool drive with a minimum output of 300 watts.

#### Ordering notes:

- For POS type, please add "POS" to the description.

D [mm]	D <sub>c</sub> [mm]	L <sub>t</sub> [mm]	D <sub>f</sub> [mm]	L [mm]	Packaging		Opt. RPM	Max. RPM	Description
					10x 1	10			
					EAN 4007220				

#### Steel wire (ST)

10	10	20	0.20	65	-	530887	10,000–15,000	20,000	PBU 1010/6 ST 0,20
			0.35	65	-	153277			
13	12	20	0.20	65	-	562574	10,000–15,000	20,000	PBU 1312/6 ST 0,20
			0.35	65	-	562581			
15	16	22	0.20	65	894491	530894	9,000–13,500	18,000	PBU 1516/6 ST 0,20
			0.35	65	532256	153253			
20	22	25	0.20	70	894514	530900	9,000–13,500	18,000	PBU 2022/6 ST 0,20
			0.50	70	532263	153222			
30	29	25	0.20	70	-	530917	7,500–11,300	15,000	PBU 3029/6 ST 0,20
			0.50	70	-	153192			

#### Stainless steel wire (INOX)

Supplied with plastic-covered brush body. All INOX brushes are degreased.

10	10	20	0.15	65	-	598023	8,000–13,000	20,000	PBU 1010/6 INOX 0,15			
			0.20	65	-	530924				8,000–13,000	20,000	PBU 1010/6 INOX 0,20
			0.35	65	-	153291				8,000–13,000	20,000	PBU 1010/6 INOX 0,35
13	12	20	0.15	65	-	598030	8,000–13,000	20,000	PBU 1312/6 INOX 0,15			
			0.20	65	-	562598				8,000–13,000	20,000	PBU 1312/6 INOX 0,20
			0.35	65	-	562604				8,000–13,000	20,000	PBU 1312/6 INOX 0,35
15	16	22	0.15	65	-	598047	7,200–11,700	18,000	PBU 1516/6 INOX 0,15			
			0.20	65	894545	530931				7,200–11,700	18,000	PBU 1516/6 INOX 0,20
			0.35	65	532287	153260				7,200–11,700	18,000	PBU 1516/6 INOX 0,35
20	22	25	0.15	70	-	598054	7,200–11,700	18,000	PBU 2022/6 INOX 0,15			
			0.20	70	894552	530948				7,200–11,700	18,000	PBU 2022/6 INOX 0,20
			0.50	70	532294	153246				7,200–11,700	18,000	PBU 2022/6 INOX 0,50
30	29	25	0.15	70	-	598061	6,000–9,800	15,000	PBU 3029/6 INOX 0,15			
			0.20	70	-	530955				6,000–9,800	15,000	PBU 3029/6 INOX 0,20
			0.50	70	-	153215				6,000–9,800	15,000	PBU 3029/6 INOX 0,50

#### Brass wire (MES)

10	10	20	0.30	65	-	153284	8,000–13,000	20,000	PBU 1010/6 MES 0,30
13	12	20	0.30	65	-	562611	8,000–13,000	20,000	PBU 1312/6 MES 0,30
15	16	22	0.30	65	-	220672	7,200–11,700	18,000	PBU 1516/6 MES 0,30
20	22	25	0.50	70	-	153239	7,200–11,700	18,000	PBU 2022/6 MES 0,50
30	29	25	0.50	70	-	153208	6,000–9,800	15,000	PBU 3029/6 MES 0,50

#### Silicon carbide (SiC) plastic filament

10	10	20	0.90	65	-	220696	8,000–13,000	20,000	PBU 1010/6 SiC 180 0,90
13	12	20	0.90	65	-	562628	8,000–13,000	20,000	PBU 1312/6 SiC 180 0,90
15	16	22	0.90	65	532348	220689	7,200–11,700	18,000	PBU 1516/6 SiC 180 0,90
20	22	25	0.90	70	532355	220665	7,200–11,700	18,000	PBU 2022/6 SiC 180 0,90
30	29	25	0.90	70	-	220658	6,000–9,800	15,000	PBU 3029/6 SiC 180 0,90



## PBUL, long / PBUS, tapered

Suitable for light brushing such as deburring, cleaning and derusting.  
Special versions for particular applications.

**PBUL:** Particularly long version to access deep gaps.

**PBUS:** Tapered tip for superb accuracy.

### Advantages:

- Optimal access to hard-to-reach areas.

### Recommendations for use:

- For the best results, use a tool drive with a minimum output of 300 watts.

### Ordering notes:

- Please complete the description with the desired filament material diameter ( $D_f$ ).

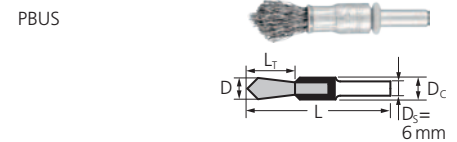
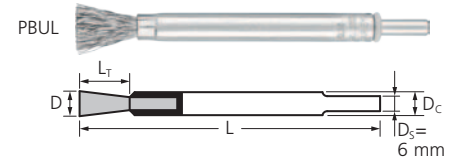

D [mm]	D <sub>C</sub> [mm]	L <sub>T</sub> [mm]	L [mm]	D <sub>f</sub> [mm]		Opt. RPM	Max. RPM	IP	Description
				0.20	0.30				
				EAN 4007220					

### Steel wire (ST)

10	10	20	120	659199	659205	4,000–9,500	20,000	10	PBUL 1010/6 ST ...
			60	-	659243	10,000–15,000	20,000	10	PBUS 1010/6 ST ...

### Stainless steel wire (INOX)

Supplied with plastic-covered brush body. All INOX brushes are degreased.

10	10	20	120	659212	659229	3,500–9,000	20,000	10	PBUL 1010/6 INOX ...
			60	-	659250	8,000–13,000	20,000	10	PBUS 1010/6 INOX ...

## PBV, encapsulated

Suitable for medium-duty brushing such as deburring, cleaning and derusting.

### Advantages:

- Focused working thanks to high dimensional stability.
- Longest tool life as premature wire breakage is prevented.

### Recommendations for use:

- For the best results, use a tool drive with a minimum output of 300 watts.
- Use face-down for a particularly intensive brushing effect.

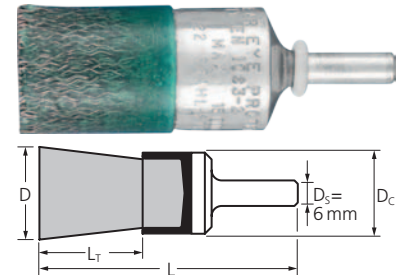

D [mm]	D <sub>C</sub> [mm]	L <sub>T</sub> [mm]	D <sub>f</sub> [mm]	L [mm]	Packaging	Opt. RPM	Max. RPM	Description
					10			
					EAN 4007220			

### Steel wire (ST)

22	22	25	0.25	70	153321	6,500–9,800	13,000	PBV 2222/6 ST 0,25
30	29	25	0.35	70	531112	6,500–9,800	13,000	PBV 3029/6 ST 0,35



# Shank mounted end brushes

## crimped

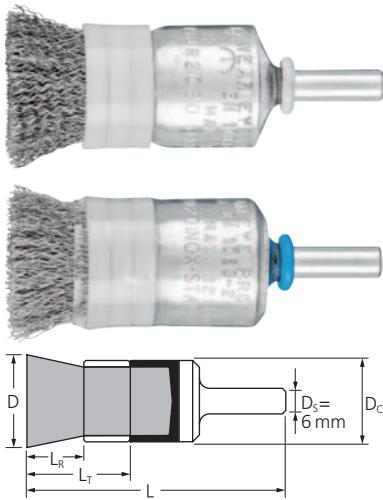

### PBUR, with bridle

Suitable for light brushing such as deburring, cleaning and derusting.



#### Advantages:

- The bridle prevents the wires spreading out sideways.
- The bridle enables the spreading out and flexibility of the brush filament to be strictly controlled.
- Optimal access to hard-to-reach areas such as recesses and drilled holes.

#### Recommendations for use:

- For the best results, use a tool drive with a minimum output of 300 watts.

#### Ordering notes:

- Please complete the description with the desired filament material diameter ( $D_f$ ).

D [mm]	$D_c$ [mm]	$L_r$ [mm]	$L_t$ [mm]	L [mm]	$D_f$ [mm]		Opt. RPM	Max. RPM		Description	
					0.20	0.35					
					EAN 4007220						

#### Steel wire (ST)

13	16	13	25	70	530962	530979	7,500–11,300	15,000	10	PBUR 1316/6 ST ...
20	22	13	25	70	530986	530993	6,300–9,400	12,500	10	PBUR 2022/6 ST ...
25	30	13	25	70	531006	531013	6,300–9,400	12,500	10	PBUR 2530/6 ST ...

#### Stainless steel wire (INOX)

Supplied with plastic-covered brush body. All INOX brushes are degreased.

13	16	13	25	70	531020	-	6,000–9,800	15,000	10	PBUR 1316/6 INOX ...
20	22	13	25	70	531037	-	5,000–8,100	12,500	10	PBUR 2022/6 INOX ...
25	30	13	25	70	531044	-	5,000–8,100	12,500	10	PBUR 2530/6 INOX ...

## knotted

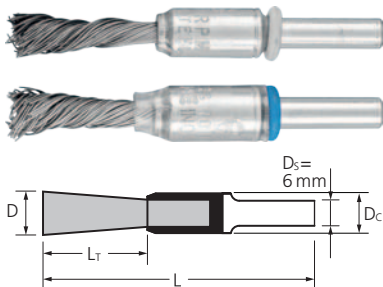

### PBGS, SINGLETWIST

Particularly flexible single-knot brush for special applications.



#### Advantages:

- Optimal access to hard-to-reach areas such as inside corners as the knot is less likely to unravel.

#### Recommendations for use:

- For optimum results, use on speed-adjustable tool drives.
- For the best results, use a tool drive with a minimum output of 300 watts.

#### Ordering notes:

- Please complete the description with the desired filament material diameter ( $D_f$ ).

D [mm]	$D_c$ [mm]	$L_r$ [mm]	$L_t$ [mm]	L [mm]	$D_f$ [mm]			Opt. RPM	Max. RPM		Description
					0.20	0.35	0.50				
					EAN 4007220						

#### Steel wire (ST) – SINGLETWIST type

10	10	25	65	659267	659274	659281	5,000–7,500	10,000	10	PBGS 1010/6 ST ...
12	10	28	71	807002	-	-	5,000–7,500	10,000	10	PBGS 1210/6 ST ...

#### Stainless steel wire (INOX) – SINGLETWIST type

Supplied with plastic-covered brush body. All INOX brushes are degreased.

10	10	25	65	659298	659304	659311	4,000–6,500	10,000	10	PBGS 1010/6 INOX ...
12	10	28	71	807019	-	-	4,000–6,500	10,000	10	PBGS 1210/6 INOX ...

### PBG

Aggressive brush. Suitable for medium-duty brushing such as deburring, cleaning and derusting.

#### Advantages:

- Optimal access to hard-to-reach areas such as recesses and drilled holes.

#### Recommendations for use:

- Use speed-adjustable tool drives to control the spread of the brush.
- For the best results, use a tool drive with a minimum output of 500 watts.

#### Ordering notes:

- For POS type, please add "POS" to the description.

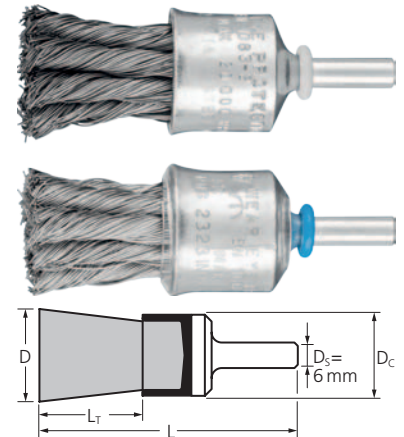

D [mm]	D <sub>c</sub> [mm]	L <sub>T</sub> [mm]	D <sub>F</sub> [mm]	L [mm]	Knots [pcs.]	Packaging		Opt. RPM	Max. RPM	Description	
						10x 	10 				
						EAN 4007220					

#### Steel wire (ST)

19	19	28	0.25	68	6	-	936580	10,000–15,000	20,000	PBG 1919/6 ST 0,25
			0.35	68	6	532416	153314	10,000–15,000	20,000	PBG 1919/6 ST 0,35
			0.50	68	6	894361	531051	10,000–15,000	20,000	PBG 1919/6 ST 0,50
23	23	28	0.25	68	8	-	936603	10,000–15,000	20,000	PBG 2323/6 ST 0,25
			0.35	68	8	-	936610	10,000–15,000	20,000	PBG 2323/6 ST 0,35
			0.50	68	8	-	936627	10,000–15,000	20,000	PBG 2323/6 ST 0,50
30	28	25	0.25	68	12	-	936672	8,000–11,300	20,000	PBG 3028/6 ST 0,25
			0.35	68	12	532423	531068	8,000–11,300	20,000	PBG 3028/6 ST 0,35
			0.50	68	12	894422	531075	8,000–11,300	20,000	PBG 3028/6 ST 0,50

#### Stainless steel wire (INOX)

Supplied with plastic-covered brush body. All INOX brushes are degreased.

19	19	28	0.15	68	6	-	598078	8,000–13,000	20,000	PBG 1919/6 INOX 0,15
			0.25	68	6	-	936597	8,000–13,000	20,000	PBG 1919/6 INOX 0,25
			0.35	68	6	532430	220702	8,000–13,000	20,000	PBG 1919/6 INOX 0,35
			0.60	68	6	-	531082	8,000–13,000	20,000	PBG 1919/6 INOX 0,60
23	23	28	0.15	68	8	-	936634	8,000–13,000	20,000	PBG 2323/6 INOX 0,15
			0.25	68	8	-	936641	8,000–13,000	20,000	PBG 2323/6 INOX 0,25
			0.35	68	8	-	936658	8,000–13,000	20,000	PBG 2323/6 INOX 0,35
			0.60	68	8	-	936665	8,000–13,000	20,000	PBG 2323/6 INOX 0,60
30	28	25	0.15	68	12	-	598085	6,000–9,800	20,000	PBG 3028/6 INOX 0,15
			0.25	68	12	-	936689	6,000–9,800	20,000	PBG 3028/6 INOX 0,25
			0.35	68	12	532447	531099	6,000–9,800	20,000	PBG 3028/6 INOX 0,35
			0.60	68	12	-	531105	6,000–9,800	20,000	PBG 3028/6 INOX 0,60





# Shank mounted cup brushes

## crimped

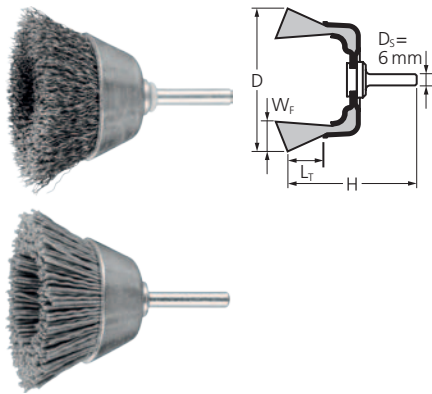

### TBU

Universally suitable for cleaning, derusting and smoothing, as well as removal of corrosion and paint. Particularly suitable for brushing on large, flat and easily accessible surfaces due to face-down use with the entire brush face applied to the workpiece.

#### Advantages:

- Highly flexible, enabling optimal adjustment to the workpiece contour.

#### Ordering notes:

- For POS type, please add "POS" to the description.

#### Recommendations for use:

- For the best results, use a tool drive with a minimum output of 300 watts.

D [mm]	W <sub>F</sub> [mm]	L <sub>T</sub> [mm]	D <sub>F</sub> [mm]	H [mm]	Packaging		Opt. RPM	Max. RPM	Description
					5x 1	10			
					EAN 4007220				

#### Steel wire (ST)

30	10	15	0.20	60	-	004517	5,300–7,900	10,500	TBU 3010/6 ST 0,20
40	15	20	0.20	70	-	004524	5,300–7,900	10,500	TBU 4015/6 ST 0,20
50	10	20	0.30	75	532171	153345	5,300–7,900	10,500	TBU 5010/6 ST 0,30
60	15	20	0.30	85	-	153352	2,200–3,400	4,500	TBU 6015/6 ST 0,30
70	15	22	0.20	80	-	004531	3,000–4,500	6,000	TBU 7015/6 ST 0,20
			0.30	80	-	004555	3,000–4,500	6,000	TBU 7015/6 ST 0,30

#### Stainless steel wire (INOX)

Supplied with plastic covered brush body.

30	10	15	0.20	60	-	004562	4,200–6,800	10,500	TBU 3010/6 INOX 0,20
40	15	20	0.20	70	-	004579	4,200–6,800	10,500	TBU 4015/6 INOX 0,20
50	10	20	0.30	75	894651	579107	4,200–6,800	10,500	TBU 5010/6 INOX 0,30
60	15	20	0.30	85	-	579114	1,800–2,900	4,500	TBU 6015/6 INOX 0,30
70	15	22	0.20	80	-	004586	2,400–4,000	6,000	TBU 7015/6 INOX 0,20
			0.30	80	-	004593	2,400–4,000	6,000	TBU 7015/6 INOX 0,30

#### Silicon carbide (SiC) plastic filament

50	10	20	0.90	75	894668	220719	4,200–6,800	10,500	TBU 5010/6 SiC 180 0,90
60	15	20	0.90	85	-	220726	1,800–2,900	4,500	TBU 6015/6 SiC 180 0,90

#### Ceramic oxide grain (CO) plastic filament

50	15	22	1.10	75	-	004609	4,200–6,800	10,500	TBU 5015/6 CO 120 1,10
----	----	----	------	----	---	--------	-------------	--------	------------------------

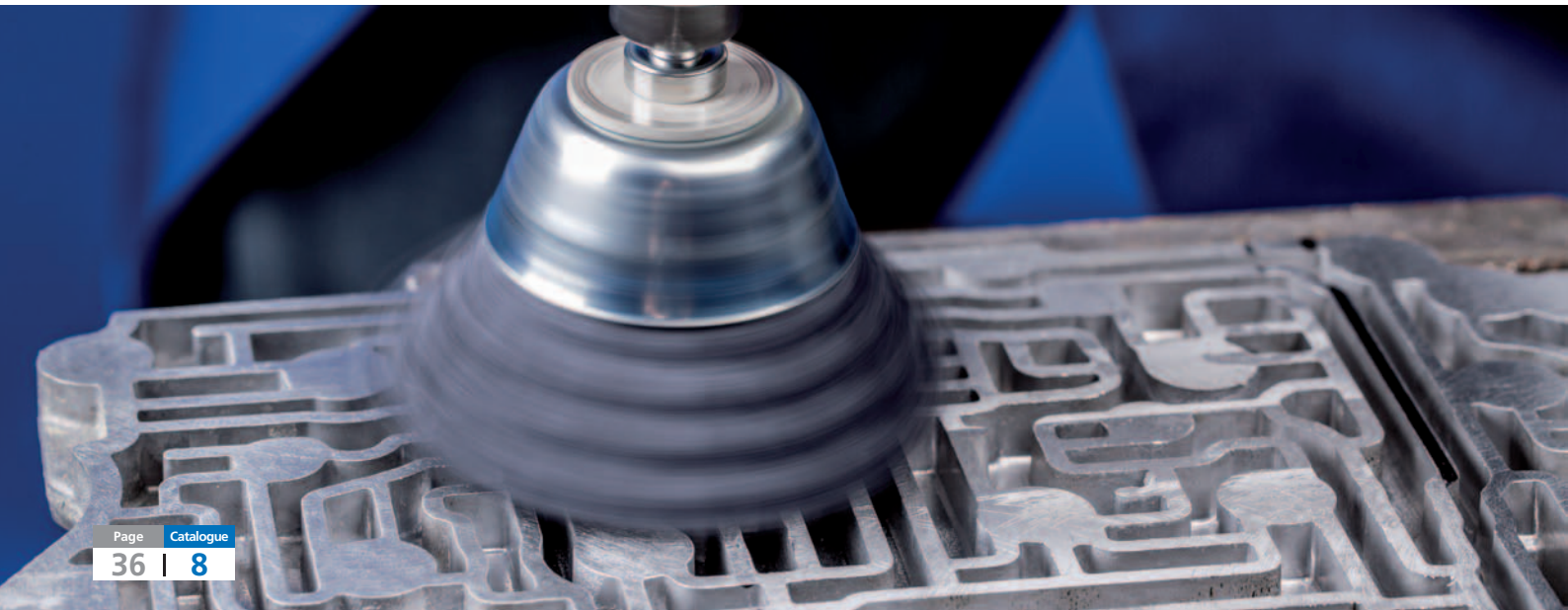

## KBU

Excellent for medium-duty brushing such as deburring, cleaning and derusting.



### Advantages:

- Optimal access to hard-to-reach areas such as inner edges, grooves and keyways.

### Recommendations for use:

- For the best results, use a tool drive with a minimum output of 300 watts.

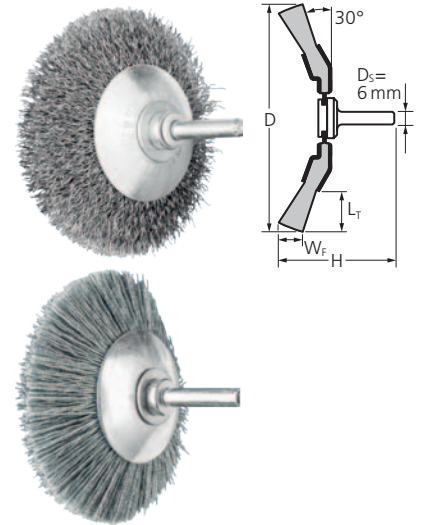

D [mm]	W <sub>f</sub> [mm]	L <sub>T</sub> [mm]	D <sub>f</sub> [mm]	H [mm]	Packaging	Opt. RPM	Max. RPM	Description
					 EAN 4007220			

### Steel wire (ST)

50	10	10	0.20	49	936351	7,500–11,300	15,000	KBU 5010/6 ST 0,20
70	10	15	0.30	58	936368	7,500–11,300	15,000	KBU 7010/6 ST 0,30
80	10	20	0.30	62	936375	6,000–9,000	12,000	KBU 8010/6 ST 0,30
95	10	25	0.30	62	899397	6,000–9,000	12,000	KBU 9510/6 ST 0,30

### Stainless steel wire (INOX)

All INOX brushes are degreased.

50	10	10	0.20	49	936382	6,000–9,800	15,000	KBU 5010/6 INOX 0,20
70	10	15	0.15	58	936399	6,000–9,800	15,000	KBU 7010/6 INOX 0,15
			0.20	58	936405	6,000–9,800	15,000	KBU 7010/6 INOX 0,20
80	10	20	0.30	62	936412	4,800–7,800	12,000	KBU 8010/6 INOX 0,30
95	10	25	0.30	62	899403	4,800–7,800	12,000	KBU 9510/6 INOX 0,30

### Silicon carbide (SiC) plastic filament

70	10	15	0.55	58	004456	6,000–9,800	15,000	KBU 7010/6 SiC 120 0,55
80	10	20	0.55	62	004470	4,800–7,800	12,000	KBU 8010/6 SiC 120 0,55
95	10	25	1.10	62	004494	4,800–7,800	12,000	KBU 9510/6 SiC 120 1,10

### Ceramic oxide grain (CO) plastic filament

70	10	15	0.55	58	004463	6,000–9,800	15,000	KBU 7010/6 CO 120 0,55
80	10	20	0.55	62	004487	4,800–7,800	12,000	KBU 8010/6 CO 120 0,55
95	10	25	1.10	62	004500	4,800–7,800	12,000	KBU 9510/6 CO 120 1,10



# Shank mounted wheel brushes

## crimped

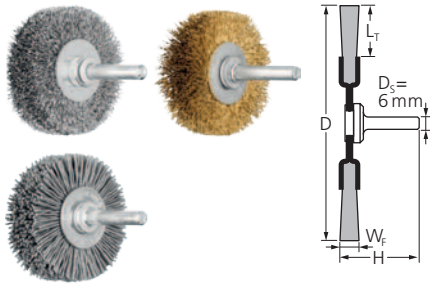

### RBU

Universally suitable for cleaning, derusting, smoothing, cleaning of weld seams, light deburring, and removal of corrosion and paint.

#### Advantages:



- Highly flexible, enabling optimal adjustment to the workpiece contour.

#### Recommendations for use:

- For the best results, use a tool drive with a minimum output of 300 watts.

#### Ordering notes:

- For POS type, please add "POS" to the description.

D [mm]	W <sub>F</sub> [mm]	L <sub>T</sub> [mm]	D <sub>F</sub> [mm]	H [mm]	Packaging		Opt. RPM	Max. RPM	Description
					10x 				
					EAN 4007220				

#### Steel wire (ST)

20	4	3	0.20	37	-	152980	10,000–15,000	20,000	RBU 2004/6 ST 0,20
30	6	7	0.20	40	531808	153017	10,000–15,000	20,000	RBU 3006/6 ST 0,20
	9	7	0.20	42	-	899250	10,000–15,000	20,000	RBU 3009/6 ST 0,20
40	9	9	0.20	46	-	153048	9,000–13,500	18,000	RBU 4009/6 ST 0,20
50	4	9	0.20	41	-	806593	7,500–11,300	15,000	RBU 5004/6 ST 0,20
	10	13	0.20	50	-	104767	7,500–11,300	15,000	RBU 5010/6 ST 0,20
	15	13	0.20	50	531822	153079	7,500–11,300	15,000	RBU 5015/6 ST 0,20
60	10	15	0.20	50	-	104781	7,500–11,300	15,000	RBU 6010/6 ST 0,20
	15	15	0.20	50	-	658437	7,500–11,300	15,000	RBU 6015/6 ST 0,20
70	4	9	0.20	41	-	806609	7,500–11,300	15,000	RBU 7004/6 ST 0,20
	10	19	0.30	50	-	658444	7,500–11,300	15,000	RBU 7010/6 ST 0,30
	15	19	0.30	50	894606	153109	7,500–11,300	15,000	RBU 7015/6 ST 0,30
80	4	10	0.20	41	-	806616	6,000–9,000	12,000	RBU 8004/6 ST 0,20
	15	19	0.30	50	-	153130	6,000–9,000	12,000	RBU 8015/6 ST 0,30
100	10	25	0.30	50	894613	658451	6,000–9,000	12,000	RBU 10010/6 ST 0,30

#### Stainless steel wire (INOX)

20	4	3	0.20	37	-	153000	8,000–13,000	20,000	RBU 2004/6 INOX 0,20
30	6	7	0.20	40	531884	153031	8,000–13,000	20,000	RBU 3006/6 INOX 0,20
	9	7	0.20	42	-	899267	8,000–13,000	20,000	RBU 3009/6 INOX 0,20
40	9	9	0.20	46	-	153062	7,200–11,700	18,000	RBU 4009/6 INOX 0,20
50	4	9	0.20	41	-	806623	6,000–9,800	15,000	RBU 5004/6 INOX 0,20
	10	13	0.20	50	-	104774	6,000–9,800	15,000	RBU 5010/6 INOX 0,20
	15	13	0.20	50	531891	153093	6,000–9,800	15,000	RBU 5015/6 INOX 0,20
60	10	15	0.20	50	-	104798	6,000–9,800	15,000	RBU 6010/6 INOX 0,20
	15	15	0.20	50	-	658468	6,000–9,800	15,000	RBU 6015/6 INOX 0,20
70	4	9	0.20	41	-	806630	6,000–9,800	15,000	RBU 7004/6 INOX 0,20
	10	19	0.20	50	-	597835	6,000–9,800	15,000	RBU 7010/6 INOX 0,20
	15	19	0.15	50	-	597842	6,000–9,800	15,000	RBU 7015/6 INOX 0,15
80	15	19	0.30	50	894620	153123	6,000–9,800	15,000	RBU 7015/6 INOX 0,30
	4	10	0.20	41	-	806647	4,800–7,800	12,000	RBU 8004/6 INOX 0,20
	10	19	0.20	50	-	578919	4,800–7,800	12,000	RBU 8010/6 INOX 0,20
100	15	19	0.15	50	-	597859	4,800–7,800	12,000	RBU 8015/6 INOX 0,15
	15	19	0.30	50	-	153154	4,800–7,800	12,000	RBU 8015/6 INOX 0,30
	10	25	0.30	50	894637	658475	4,800–7,800	12,000	RBU 10010/6 INOX 0,30

#### Brass wire (MES)

20	4	3	0.20	37	-	152997	8,000–13,000	20,000	RBU 2004/6 MES 0,20
30	6	7	0.20	40	-	153024	8,000–13,000	20,000	RBU 3006/6 MES 0,20
40	9	9	0.20	46	-	153055	7,200–11,700	18,000	RBU 4009/6 MES 0,20
50	15	13	0.20	50	-	153086	6,000–9,800	15,000	RBU 5015/6 MES 0,20
70	15	19	0.30	50	-	153116	6,000–9,800	15,000	RBU 7015/6 MES 0,30
80	15	19	0.30	50	-	153147	4,800–7,800	12,000	RBU 8015/6 MES 0,30

Continued on next page



D [mm]	W <sub>F</sub> [mm]	L <sub>T</sub> [mm]	D <sub>F</sub> [mm]	H [mm]	Packaging		Opt. RPM	Max. RPM	Description
					10x 1	10			

### Silicon carbide (SiC) plastic filament

50	4	10	0.55	50	-	936511	6,000–9,800	15,000	RBV 5004/6 SiC 120 0,55
50	10	13	0.90	50	-	104750	6,000–9,800	15,000	RBV 5010/6 SiC 180 0,90
	15	13	0.90	50	531945	220610	6,000–9,800	15,000	RBV 5015/6 SiC 180 0,90
70	8	19	0.55	50	-	936528	6,000–9,800	15,000	RBV 7008/6 SiC 120 0,55
	15	19	0.90	50	894644	220627	6,000–9,800	15,000	RBV 7015/6 SiC 180 0,90
80	8	19	0.55	50	-	936535	4,800–7,800	12,000	RBV 8008/6 SiC 120 0,55
	15	19	0.90	50	-	220634	4,800–7,800	12,000	RBV 8015/6 SiC 180 0,90

### Ceramic oxide green (CO) plastic filament

50	4	10	0.55	50	-	936542	6,000–9,800	15,000	RBV 5004/6 CO 120 0,55
	15	13	1.10	50	-	899342	6,000–9,800	15,000	RBV 5015/6 CO 120 1,10
70	8	19	0.55	50	-	936559	6,000–9,800	15,000	RBV 7008/6 CO 120 0,55
	15	19	1.10	50	-	899359	6,000–9,800	15,000	RBV 7015/6 CO 120 1,10
80	8	19	0.55	50	-	936566	4,800–7,800	12,000	RBV 8008/6 CO 120 0,55
	15	19	1.10	50	-	899366	4,800–7,800	12,000	RBV 8015/6 CO 120 1,10

### RBV, encapsulated

Suitable for medium-duty brushing such as deburring, cleaning and derusting.

#### Advantages:

- Focused working thanks to high dimensional stability.

#### Recommendations for use:

- For the best results, use a tool drive with a minimum output of 300 watts.

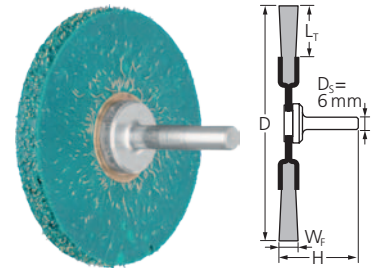

D [mm]	W <sub>F</sub> [mm]	L <sub>T</sub> [mm]	D <sub>F</sub> [mm]	H [mm]	Packaging		Opt. RPM	Max. RPM	Description
					1				

### Steel wire (ST)

ST = brass-plated steel wire

63	7	20	0.30	40	220955	7,500–11,300	15,000	RBV 6307/6 ST 0,30
----	---	----	------	----	--------	--------------	--------	--------------------



# Shank mounted wheel brushes

## knotted

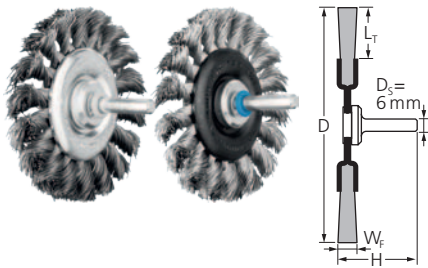

### RBG

Aggressive brush for cleaning, derusting and work on weld seams.



#### Advantages:



- Optimal access to hard-to-reach areas such as grooves and recesses.
- Aggressive brushing effect due to the very stiff wire knots.

#### Recommendations for use:

- For the best results, use a tool drive with a minimum output of 500 watts.

#### Ordering notes:

- For POS type, please add "POS" to the description.

D [mm]	W <sub>f</sub> [mm]	L <sub>T</sub> [mm]	D <sub>f</sub> [mm]	H [mm]	Knots [pcs.]	Packaging		Opt. RPM	Max. RPM	Description	
						10x 					
						EAN 4007220					

#### Steel wire (ST)

76	6	16	0.35	42	18	531969	153161	12,500–18,800	25,000	RBG 7006/6 ST 0,35
	6	16	0.50	42	18	894569	530177	12,500–18,800	25,000	RBG 7006/6 ST 0,50
	12	16	0.35	42	18	-	658482	12,500–18,800	25,000	RBG 7012/6 ST 0,35
	12	16	0.50	42	18	-	658680	12,500–18,800	25,000	RBG 7012/6 ST 0,50
100	12	19	0.35	42	22	-	530351	10,000–15,000	20,000	RBG 10012/6 ST 0,35
			0.50	42	22	-	530399	10,000–15,000	20,000	RBG 10012/6 ST 0,50

#### Stainless steel wire (INOX)

All INOX brushes are degreased.

76	6	16	0.35	42	18	531976	220641	10,000–16,300	25,000	RBG 7006/6 INOX 0,35
	6	16	0.50	42	18	-	530603	10,000–16,300	25,000	RBG 7006/6 INOX 0,50
	12	16	0.35	42	18	-	658697	10,000–16,300	25,000	RBG 7012/6 INOX 0,35
	12	16	0.50	42	18	-	659472	10,000–16,300	25,000	RBG 7012/6 INOX 0,50
100	12	19	0.35	42	22	-	530405	8,000–13,000	20,000	RBG 10012/6 INOX 0,35
			0.50	42	22	-	530610	8,000–13,000	20,000	RBG 10012/6 INOX 0,50

## Brush sets



### BSO

Set with different wheel, cup and end brushes with a 6 mm shank.

One BSO 5500 ST set contains 80 pieces:

- 10 x RBU 3006/6 ST 0,20
- 10 x RBU 4009/6 ST 0,20
- 10 x RBU 5015/6 ST 0,20
- 10 x RBU 7015/6 ST 0,30
- 10 x TBU 5010/6 ST 0,30
- 10 x PBU 1010/6 ST 0,35
- 10 x PBU 1516/6 ST 0,35
- 10 x PBU 2020/6 ST 0,50

One BSO 5600 ST set contains 23 pieces:

- 4 x TBU 5010/6 ST 0,30
- 10 x PBU 2020/6 ST 0,50
- 5 x RBU 5015/6 ST 0,20
- 4 x RBG 7006/6 ST 0,35

One BSO 5600 INOX set contains 23 pieces:

- 4 x TBU 5010/6 INOX 0,30
- 10 x PBU 2020/6 INOX 0,50
- 5 x RBU 5015/6 INOX 0,20
- 4 x RBG 7006/6 INOX 0,35

#### Advantages:

- Selection of the most common types.
- Promotional display box.

EAN 4007220		Description
220962	1	BSO 5500 ST
808368	1	BSO 5600 ST
808375	1	BSO 5600 INOX

## WBU, for burnishing machines

Excellent for surface structuring work on workpieces with large surfaces.

The special wire construction with cord wire filament (LIT) is particularly suitable for heavy-duty brushing and aggressive brushing.

### Advantages:

- Can be used with all common burnishing machines thanks to the arbor hole with 4 keyways.



D [mm]	W <sub>F</sub> [mm]	L <sub>T</sub> [mm]	D <sub>A</sub> [mm]	D <sub>F</sub> [mm]	Packaging	Opt. RPM	Max. RPM	Description
					 EAN 4007220			

### Steel wire (LIT, ST)

LIT ST = stranded, brass-plated steel wire

100	100	26	19.1	0.27	773086	3,000–4,500	6,000	WBU 100100/19,1 LIT ST 0,27
-----	-----	----	------	------	--------	-------------	-------	-----------------------------

### Stainless steel wire (INOX)

100	100	26	19.1	0.20	773079	2,400–3,900	6,000	WBU 100100/19,1 INOX 0,20
-----	-----	----	------	------	--------	-------------	-------	---------------------------

### Silicon carbide (SiC) plastic filament

100	100	26	19.1	1.27	773062	2,400–3,900	6,000	WBU 100100/19,1 SiC 80 1,27
-----	-----	----	------	------	--------	-------------	-------	-----------------------------



For detailed information and ordering data on other drum tools and roller sets, please refer to catalogue section 4.



For detailed information and ordering data on matching drum grinders, please refer to catalogue section 9.





In addition to brushes with a stainless steel filament, PFERD also offers brushes of the INOX-TOTAL type for work on stainless steel (INOX). It is particularly well suited to use in extremely critical environments.

Further information about working with stainless steel (INOX) and PFERD INOX-TOTAL brushes can be found on page 10.

### Advantages:

- Optimum protection against corrosion as all components are produced from stainless steel (INOX) in quality 1.4310 (V2A).

### Industries:

- Chemical and plant manufacturing
- Foodstuff industry
- Nuclear industry

### Structure of a wheel brush with arbor hole INOX-TOTAL

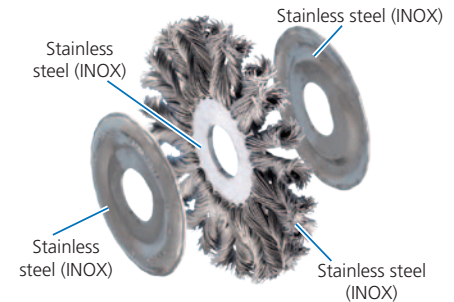

More PFERD tools and many valuable recommendations for working with stainless steel (INOX) can be found in our PRAXIS brochure "PFERD tools for use on stainless steel (INOX)". Please contact us for further details.

## Wheel brushes

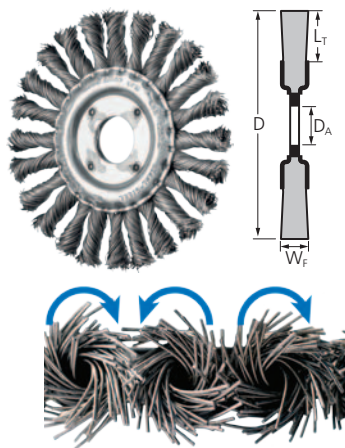

### RBGIT CT, COMBITWIST / RBGIT PIPE CT, Pipeline, COMBITWIST

**RBGIT CT:** Very aggressive brush. Suitable for heavy-duty brushing such as removal of heat discoloration, deburring, cleaning of weld seams and removal of adhesive residues.

**RBGIT PIPE CT:** Very aggressive and robust brush that is able to withstand high mechanical loads. Perfect for heavy-duty brushing in pipeline and container construction.

#### Advantages:

- Maximum economic efficiency due to the longest tool life and the highest stock removal.
- High level of comfort thanks to smooth running with no brush recoiling.
- Suitable for work on corners and edges as the knots are less likely to unravel.
- RBGIT PIPE CT: Extra-slim design enables optimal access to hard-to-reach areas such as root weld seams.

#### Recommendations for use:

- For optimum results, use on powerful speed-adjustable angle grinders.

#### PFERDVALUE:

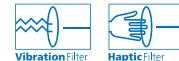

D [mm]	W <sub>F</sub> [mm]	L <sub>T</sub> [mm]	D <sub>A</sub> [mm]	D <sub>F</sub> [mm]	Knots [pcs.]	Packaging	Opt. RPM	Max. RPM	Description
						1			
<b>EAN 4007220</b>									

### Stainless steel wire (INOX) – COMBITWIST type

All INOX brushes are degreased.

115	12	22	22.2	0.35	24	808528	5,000–12,500	12,500	POS RBGIT 11512/22,2 CT INOX 0,35
	6	21	22.2	0.50	36	808511	5,000–12,500	12,500	POS RBGIT 11506/22,2 PIPE CT INOX 0,50

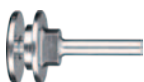

### Arbor BO 8/22,2 100-125 (EAN 4007220751930):

For knotted wheel brushes up to a diameter of 125 mm with a D<sub>A</sub> of 22.2 mm.

#### For more information:

Detailed information on accessories can be found on pages 55 and 56.

**PBUIT / PBGSIT, SINGLETWIST**

Suitable for light brushing such as deburring, cleaning, and removal of heat discoloration.

**Advantages:**

■ **PBUIT:** Optimal access to hard-to-reach areas such as drilled holes and cavities as the wires spread out upon rotation.

■ **PBGSIT:** Optimal access to hard-to-reach areas such as inside corners as the knot is less likely to unravel.

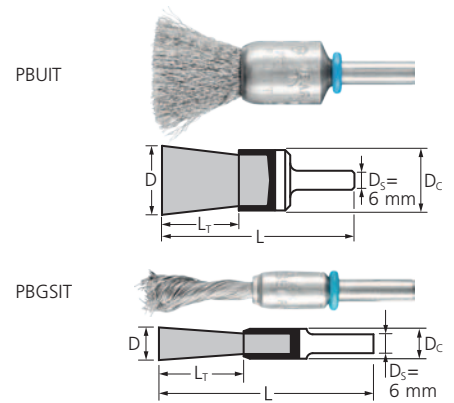

D [mm]	D <sub>c</sub> [mm]	L <sub>r</sub> [mm]	D <sub>f</sub> [mm]	L [mm]	Packaging	Opt. RPM	Max. RPM	Description
					 10 EAN 4007220			

**Stainless steel wire (INOX)**

All INOX brushes are degreased, crimped

15	16	22	0.15	65	808382	7,200–11,700	18,000	PBUIT 1516/6 INOX 0,15
			0.20	65	808399	7,200–11,700	18,000	PBUIT 1516/6 INOX 0,20
20	22	25	0.15	70	808405	7,200–11,700	18,000	PBUIT 2022/6 INOX 0,15
			0.20	70	808412	7,200–11,700	18,000	PBUIT 2022/6 INOX 0,20
knotted – SINGLETWIST knot								
10	10	25	0.20	65	808429	4,000–6,500	10,000	PBGSIT 1010/6 INOX 0,20
			0.35	65	808436	4,000–6,500	10,000	PBGSIT 1010/6 INOX 0,35

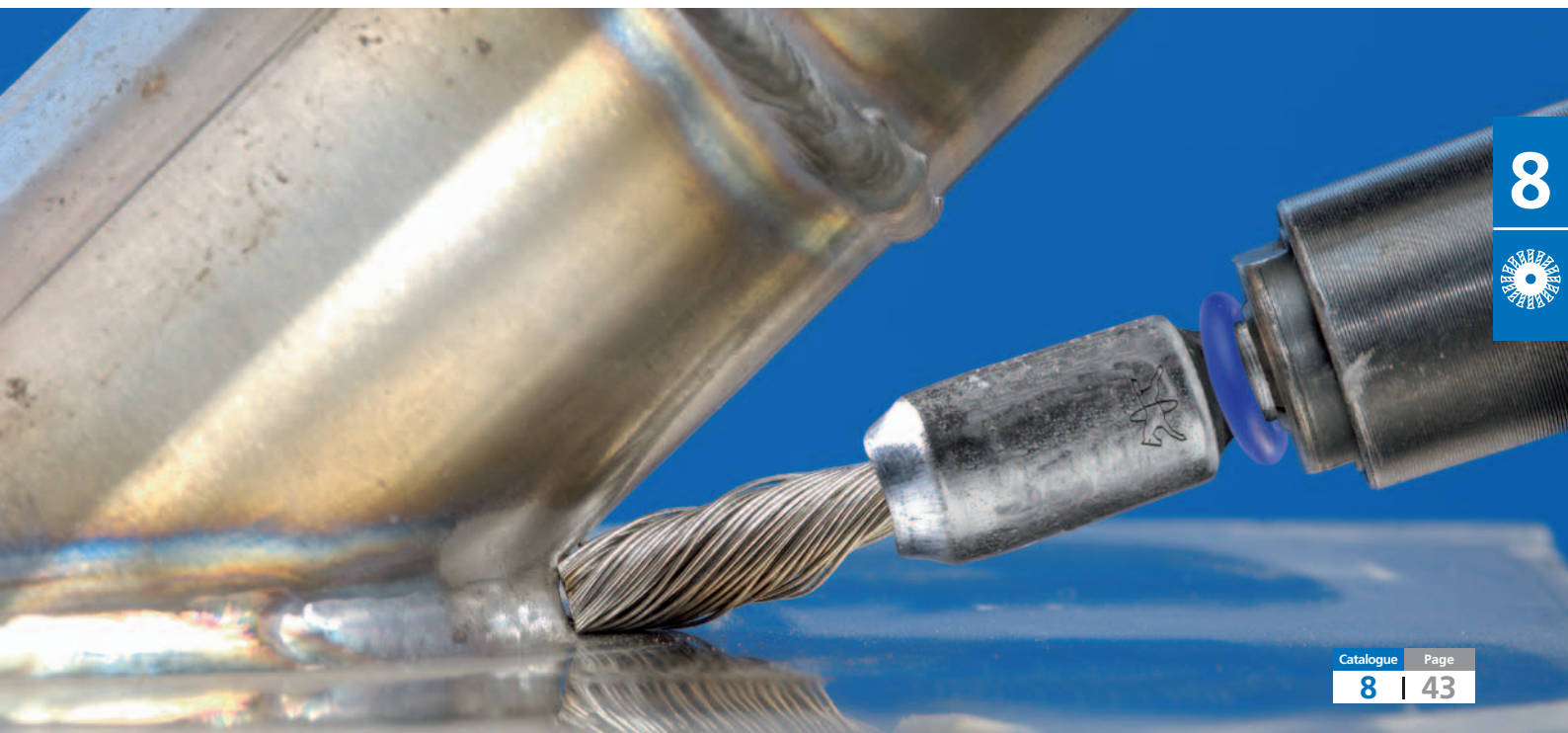

# INOX-TOTAL

## Shank mounted wheel brushes

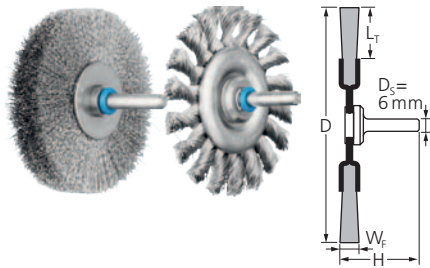

### RBUIT / RBGIT

Universally suitable for cleaning, deburring, and removal of heat discoloration.

#### Advantages:

- **RBUIT:** Highly flexible, enabling optimal adjustment to the workpiece contour.
- **RBGIT:** Aggressive brushing effect due to the very stiff wire knots.

D [mm]	W <sub>F</sub> [mm]	L <sub>T</sub> [mm]	D <sub>F</sub> [mm]	Knots [pcs.]	H [mm]	Packaging	Opt. RPM	Max. RPM	Description
						 EAN 4007220			

#### Stainless steel wire (INOX)

All INOX brushes are degreased.  
crimped

30	6	7	0.20	-	40	808443	8,000–13,000	20,000	RBUIT 3006/6 INOX 0,20
50	15	13	0.20	-	50	808450	6,000–9,800	15,000	RBUIT 5015/6 INOX 0,20
70	15	19	0.15	-	50	808467	6,000–9,800	15,000	RBUIT 7015/6 INOX 0,15
			0.30	-	50	808474	6,000–9,800	15,000	RBUIT 7015/6 INOX 0,30
80	15	19	0.15	-	50	808481	4,800–7,800	12,000	RBUIT 8015/6 INOX 0,15
			0.30	-	50	808498	4,800–7,800	12,000	RBUIT 8015/6 INOX 0,30

knotted

76	6	16	0.35	18	42	808504	10,000–16,300	25,000	RBGIT 7006/6 INOX 0,35
----	---	----	------	----	----	--------	---------------	--------	------------------------

## Shank mounted bevel brushes

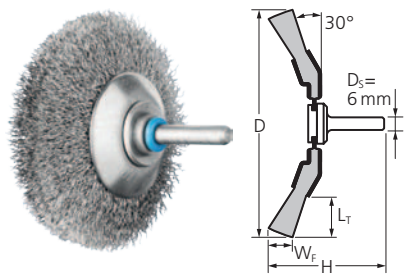

### KBUIT

Excellent for medium-duty brushing such as deburring, cleaning, and removal of heat discoloration.

#### Advantages:

- Optimal access to hard-to-reach areas such as inner edges, grooves and keyways.
- For the best results, use a tool drive with a minimum output of 300 watts.

#### Recommendations for use:

D [mm]	W <sub>F</sub> [mm]	L <sub>T</sub> [mm]	D <sub>F</sub> [mm]	H [mm]	Packaging	Opt. RPM	Max. RPM	Description
					 EAN 4007220			

#### Stainless steel wire (INOX)

All INOX brushes are degreased.

50	10	10	0.20	49	936474	6,000–9,800	15,000	KBUIT 5010/6 INOX 0,20
70	10	15	0.15	58	936481	6,000–9,800	15,000	KBUIT 7010/6 INOX 0,15
			0.20	58	936498	6,000–9,800	15,000	KBUIT 7010/6 INOX 0,20
80	10	20	0.30	62	936504	4,800–7,800	12,000	KBUIT 8010/6 INOX 0,30



PFERD offers a wide range of miniature brushes for precision work. These can be used on flexible shaft drives, micro motors or electric grinders.

### Advantages:

- Outstanding precision and efficiency in work on delicate workpieces.

### Industries:

- Medical equipment
- Jewellery sector
- Electronics industry
- Aerospace industry
- Tool and mould construction

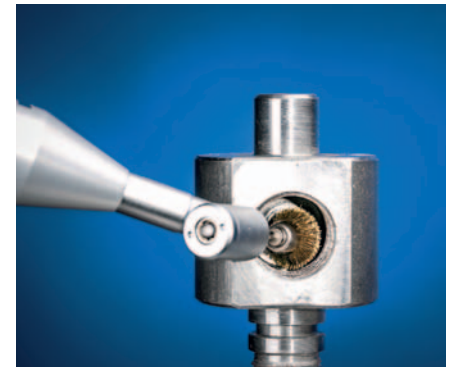

End brushes, crimped

## PBU

Suitable for light brushing such as deburring, cleaning and polishing.

### Advantages:

- Optimal access to hard-to-reach areas such as drilled holes and cavities as the wires spread out upon rotation.

### Recommendations for use:

- Use brushes with natural filaments with polishing paste to achieve the optimum polishing result. Detailed information and ordering data on polishing pastes can be found in catalogue section 4.

### Ordering notes:

- Please complete the description with the desired shank diameter ( $D_s$ ).
- Grit size DIA 400 = D 46

### Accessories:

- Polishing pastes

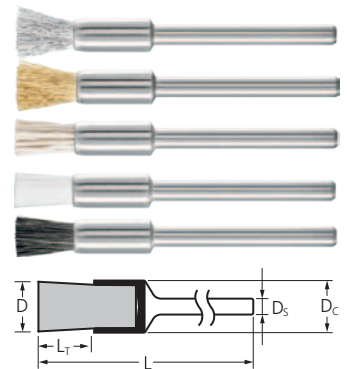

D [mm]	D <sub>c</sub> [mm]	L <sub>r</sub> [mm]	D <sub>f</sub> [mm]	L [mm]	D <sub>s</sub> [mm]		Opt. RPM	Max. RPM	IP	Description	
					2.34	3					
					EAN 4007220						
<b>Steel wire (ST)</b>											
5	5	8	0.10	45	032855	032978	5,000–15,000	25,000	10	PBU 0505/... ST 0,10	
<b>Stainless steel wire (INOX)</b>											
5	5	8	0.10	45	032879	032985	4,000–10,000	25,000	10	PBU 0505/... INOX 0,10	
<b>Brass wire (MES)</b>											
5	5	8	0.10	45	032886	032992	4,000–10,000	25,000	10	PBU 0505/... MES 0,10	
<b>Silicon carbide (SiC) plastic filament</b>											
5	5	8	0.55	45	032954	033067	1,200–5,000	25,000	10	PBU 0505/... SiC 320 0,55	
			0.25	45	032961	033074	1,200–5,000	25,000	10	PBU 0505/... SiC 800 0,25	
<b>Aluminium oxide (AO) plastic filament</b>											
5	5	8	0.50	45	032947	033050	1,200–5,000	25,000	10	PBU 0505/... AO 320 0,50	
			0.30	45	032930	033043	1,200–5,000	25,000	10	PBU 0505/... AO 600 0,30	
<b>Diamond (DIA) plastic filament</b>											
5	5	8	0.40	45	-	072844	1,200–5,000	25,000	10	PBU 0505/... DIA 400 0,40	
<b>Nylon plastic filament</b>											
5	5	8	0.20	45	032923	033036	1,200–5,000	25,000	10	PBU 0505/... Nylon 0,20	
<b>Natural bristles white (SBW)</b>											
5	5	8	-	45	032893	033005	4,000–10,000	25,000	10	PBU 0505/... SBW	
<b>Natural bristles black (SBS)</b>											
5	5	8	-	45	032909	033012	4,000–10,000	25,000	10	PBU 0505/... SBS	
<b>Natural bristles goat hair (ZHW)</b>											
5	5	8	-	45	032916	033029	4,000–10,000	25,000	10	PBU 0505/... ZHW	

Brushes with a shank diameter of 3.18 mm are available on request.



# Miniature brushes

## Cup brushes, crimped

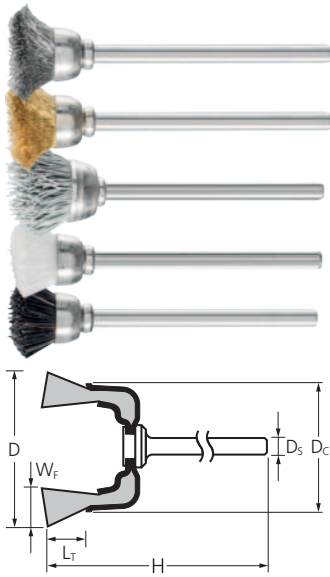

### TBU

Suitable for light brushing such as deburring, cleaning and polishing. Particularly suitable for brushing on small surfaces due to face-down use with the entire brush face applied to the workpiece.



#### Advantages:

- Highly flexible, enabling optimal adjustment to the workpiece contour.

#### Recommendations for use:

- Use brushes with natural filaments with polishing paste to achieve the optimum polishing result. Detailed information and ordering data on polishing pastes can be found in catalogue section 4.

#### Ordering notes:

- Please complete the description with the desired shank diameter ( $D_s$ ).
- Grit size DIA 400 = D 46

#### Accessories:

- Polishing pastes

D [mm]	D <sub>c</sub> [mm]	W <sub>f</sub> [mm]	L <sub>T</sub> [mm]	D <sub>f</sub> [mm]	H [mm]	D <sub>s</sub> [mm]		Opt. RPM	Max. RPM	IP	Description
						2.34	3				
EAN 4007220											

#### Steel wire (ST)

15	8	3	5	0.10	45	033081	033289	5,000–10,000	20,000	10	TBU 1503/... ST 0,10
18	10	3	6	0.10	45	033098	033296	5,000–10,000	18,000	10	TBU 1803/... ST 0,10

#### Stainless steel wire (INOX)

15	8	3	5	0.10	45	033104	033302	4,000–10,000	20,000	10	TBU 1503/... INOX 0,10
18	10	3	6	0.10	45	033111	033319	4,000–10,000	18,000	10	TBU 1803/... INOX 0,10

#### Brass wire (MES)

15	8	3	5	0.10	45	033128	033326	4,000–10,000	20,000	10	TBU 1503/... MES 0,10
18	10	3	6	0.10	45	033135	033333	4,000–10,000	18,000	10	TBU 1803/... MES 0,10

#### Silicon carbide (SiC) plastic filament

18	10	3	6	0.55	45	033265	033456	1,200–5,000	18,000	10	TBU 1803/... SiC 320 0,55
				0.25	45	033272	033463	1,200–5,000	18,000	10	TBU 1803/... SiC 800 0,25

#### Aluminium oxide (AO) plastic filament

18	10	3	6	0.50	45	033258	033449	1,200–5,000	18,000	10	TBU 1803/... AO 320 0,50
				0.30	45	033241	033432	1,200–5,000	18,000	10	TBU 1803/... AO 600 0,30

#### Diamond (DIA) plastic filament

18	10	3	6	0.40	45	-	072950	4,000–10,000	18,000	10	TBU 1803/... DIA 400 0,40
----	----	---	---	------	----	---	--------	--------------	--------	----	---------------------------

#### Nylon plastic filament

15	8	3	5	0.15	45	033203	033388	1,200–5,000	20,000	10	TBU 1503/... Nylon 0,15
18	10	3	6	0.15	45	033210	033395	1,200–5,000	18,000	10	TBU 1803/... Nylon 0,15

#### Natural bristles white (SBW)

15	8	3	5	-	45	033142	033340	4,000–10,000	20,000	10	TBU 1503/... SBW
18	10	3	6	-	45	033159	033357	4,000–10,000	18,000	10	TBU 1803/... SBW

#### Natural bristles black (SBS)

15	8	3	5	-	45	033166	033364	4,000–10,000	20,000	10	TBU 1503/... SBS
18	10	3	6	-	45	033173	033371	4,000–10,000	18,000	10	TBU 1803/... SBS

#### Natural bristles goat hair (ZHW)

15	8	3	5	-	45	033227	033418	4,000–10,000	20,000	10	TBU 1503/... ZHW
18	10	3	6	-	45	033234	033425	4,000–10,000	18,000	10	TBU 1803/... ZHW

Brushes with a shank diameter of 3.18 mm are available on request.

**RBU**

Suitable for light brushing such as deburring, cleaning and polishing.



**Advantages:**

- Enables focused working in hard-to-reach areas.

**Recommendations for use:**

- Use brushes with natural filaments with polishing paste to achieve the optimum polishing result. Detailed information and ordering data on polishing pastes can be found in catalogue section 4.

**Ordering notes:**

- Please complete the description with the desired shank diameter (D<sub>s</sub>).
- Grit size DIA 400 = D 46

**Accessories:**

- Polishing pastes

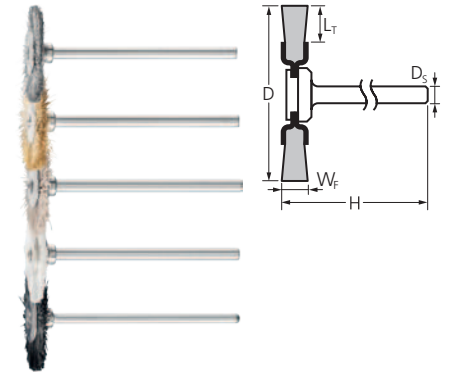

D [mm]	W <sub>F</sub> [mm]	L <sub>T</sub> [mm]	D <sub>F</sub> [mm]	H [mm]	D <sub>s</sub> [mm]		Opt. RPM	Max. RPM		Description
					2.34	3				
					EAN 4007220					
<b>Steel wire (ST)</b>										
16	2	3	0.10	46	031957	032541	5,000–10,000	12,000	10	RBU 1602/... ST 0,10
19	2	5	0.10	46	032022	032558	5,000–10,000	12,000	10	RBU 1902/... ST 0,10
22	2	6	0.10	46	032244	032565	5,000–10,000	12,000	10	RBU 2202/... ST 0,10
32	2	10	0.10	46	-	107812	5,000–10,000	12,000	10	RBU 3202/... ST 0,10
<b>Stainless steel wire (INOX)</b>										
16	2	3	0.10	46	032251	032572	4,000–10,000	12,000	10	RBU 1602/... INOX 0,10
19	2	5	0.10	46	032268	032589	4,000–10,000	12,000	10	RBU 1902/... INOX 0,10
22	2	6	0.10	46	032275	032596	4,000–10,000	12,000	10	RBU 2202/... INOX 0,10
32	2	10	0.10	46	-	107829	4,000–10,000	12,000	10	RBU 3202/... INOX 0,10
<b>Brass wire (MES)</b>										
16	2	3	0.10	46	032282	032619	4,000–10,000	12,000	10	RBU 1602/... MES 0,10
19	2	5	0.10	46	032299	032626	4,000–10,000	12,000	10	RBU 1902/... MES 0,10
22	2	6	0.10	46	032305	032602	4,000–10,000	12,000	10	RBU 2202/... MES 0,10
<b>Silicon carbide (SiC) plastic filament</b>										
22	2	6	0.55	46	032527	032763	1,200–5,000	12,000	10	RBU 2202/... SiC 320 0,55
			0.25	46	032534	032770	1,200–5,000	12,000	10	RBU 2202/... SiC 800 0,25
<b>Aluminium oxide (AO) plastic filament</b>										
22	2	6	0.50	46	032510	032756	1,200–5,000	12,000	10	RBU 2202/... AO 320 0,50
			0.30	46	032497	032749	1,200–5,000	12,000	10	RBU 2202/... AO 600 0,30
<b>Diamond (DIA) plastic filament</b>										
22	2	6	0.40	46	-	070628	1,200–5,000	12,000	10	RBU 2202/... DIA 400 0,40
<b>Nylon plastic filament</b>										
22	2	6	0.15	46	032466	032718	1,200–5,000	12,000	10	RBU 2202/... Nylon 0,15
<b>Natural bristles white (SBW)</b>										
16	2	3	-	46	032329	032633	4,000–10,000	12,000	10	RBU 1602/... SBW
19	2	5	-	46	032336	032640	4,000–10,000	12,000	10	RBU 1902/... SBW
22	2	6	-	46	032343	032657	4,000–10,000	12,000	10	RBU 2202/... SBW
<b>Natural bristles black (SBS)</b>										
16	2	3	-	46	032350	032664	4,000–10,000	12,000	10	RBU 1602/... SBS
19	2	5	-	46	032367	032688	4,000–10,000	12,000	10	RBU 1902/... SBS
22	2	6	-	46	032374	032695	4,000–10,000	12,000	10	RBU 2202/... SBS
<b>Natural bristles goat hair (ZHW)</b>										
16	2	3	-	46	032473	032725	4,000–10,000	12,000	10	RBU 1602/... ZHW
22	2	6	-	46	032480	032732	4,000–10,000	12,000	10	RBU 2202/... ZHW

Brushes with a shank diameter of 3.18 mm are available on request.



# Tube brushes

## Tube brushes

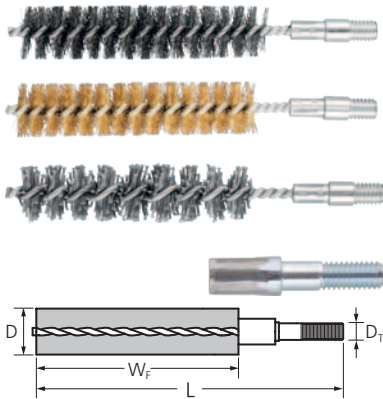

### IBU, with thread

Particularly suitable for deburring and cleaning pipes, threads, coupling sleeves and cylinders. In addition to a thread, some versions also have a shank:

M6 thread= 6 mm shank  
3/8 thread= 10 mm shank

#### Advantages:

- Can be clamped in collets thanks to integrated shank.

#### Recommendations for use:

- Insert into the workpiece before it starts to rotate.
- Use with clockwise rotation.

#### Ordering notes:

- Brushes with an SiC filament have a filament material diameter of 1.00 mm.

- Please complete the description with the desired filament material and filament material diameter ( $D_f$ ).
- BSW = British Standard Whitworth

#### Safety notes:

- When using tube brushes inside pipes, holes, grooves, etc., deviations from the specified maximum permitted rotational speed are possible in consultation with PFERD.

D [mm]	W <sub>F</sub> [mm]	D <sub>T</sub>	D <sub>F</sub> [mm]	L [mm]	Filament material				Max. RPM		Description
					Steel	INOX	Brass	SiC 180			
					EAN 4007220						
8	80	M6	0.15	120	659533	659540	659557	659564	1,000	10	IBU 0880/M6 ...
10	80	M6	0.15	120	659571	659588	659595	659601	1,000	10	IBU 1080/M6 ...
12	80	M6	0.15	120	659618	659625	659632	659649	1,000	10	IBU 1280/M6 ...
13	80	M6	0.20	120	660447	660454	660461	660478	1,000	10	IBU 1380/M6 ...
15	80	M6	0.20	120	660485	660515	660522	660539	1,000	10	IBU 1580/M6 ...
16	80	M6	0.20	120	660546	660553	660560	660577	1,000	10	IBU 1680/M6 ...
18	80	M6	0.20	120	660584	660591	660607	660614	1,000	10	IBU 1880/M6 ...
20	80	M6	0.20	120	660621	660638	660645	660652	1,000	10	IBU 2080/M6 ...
22	100	3/8	0.20	170	660669	660676	660683	660690	1,000	10	IBU 22100/3/8 BSW ...
25	100	3/8	0.20	170	660706	660713	660720	660737	1,000	10	IBU 25100/3/8 BSW ...
30	100	3/8	0.20	170	660744	660751	660768	660775	1,000	10	IBU 30100/3/8 BSW ...
32	100	1/2	0.25	170	749425	749449	749456	-	1,000	10	IBU 32100/1/2 BSW ...
38	100	1/2	0.30	170	749463	749470	749487	-	1,000	10	IBU 38100/1/2 BSW ...
40	100	1/2	0.30	170	749494	749500	749517	-	1,000	10	IBU 40100/1/2 BSW ...
44	100	1/2	0.30	170	749524	749531	749548	-	1,000	10	IBU 44100/1/2 BSW ...
50	100	1/2	0.35	170	749555	-	-	-	1,000	5	IBU 50100/1/2 BSW ...
57	100	1/2	0.35	170	749562	-	-	-	1,000	5	IBU 57100/1/2 BSW ...
63	100	1/2	0.35	170	749579	-	-	-	1,000	5	IBU 63100/1/2 BSW ...
69	100	1/2	0.35	170	749586	-	-	-	1,000	5	IBU 69100/1/2 BSW ...
75	100	1/2	0.35	170	749593	-	-	-	1,000	1	IBU 75100/1/2 BSW ...
82	100	1/2	0.35	170	749609	-	-	-	1,000	1	IBU 82100/1/2 BSW ...
101	100	1/2	0.50	170	749616	-	-	-	1,000	1	IBU 101100/1/2 BSW ...

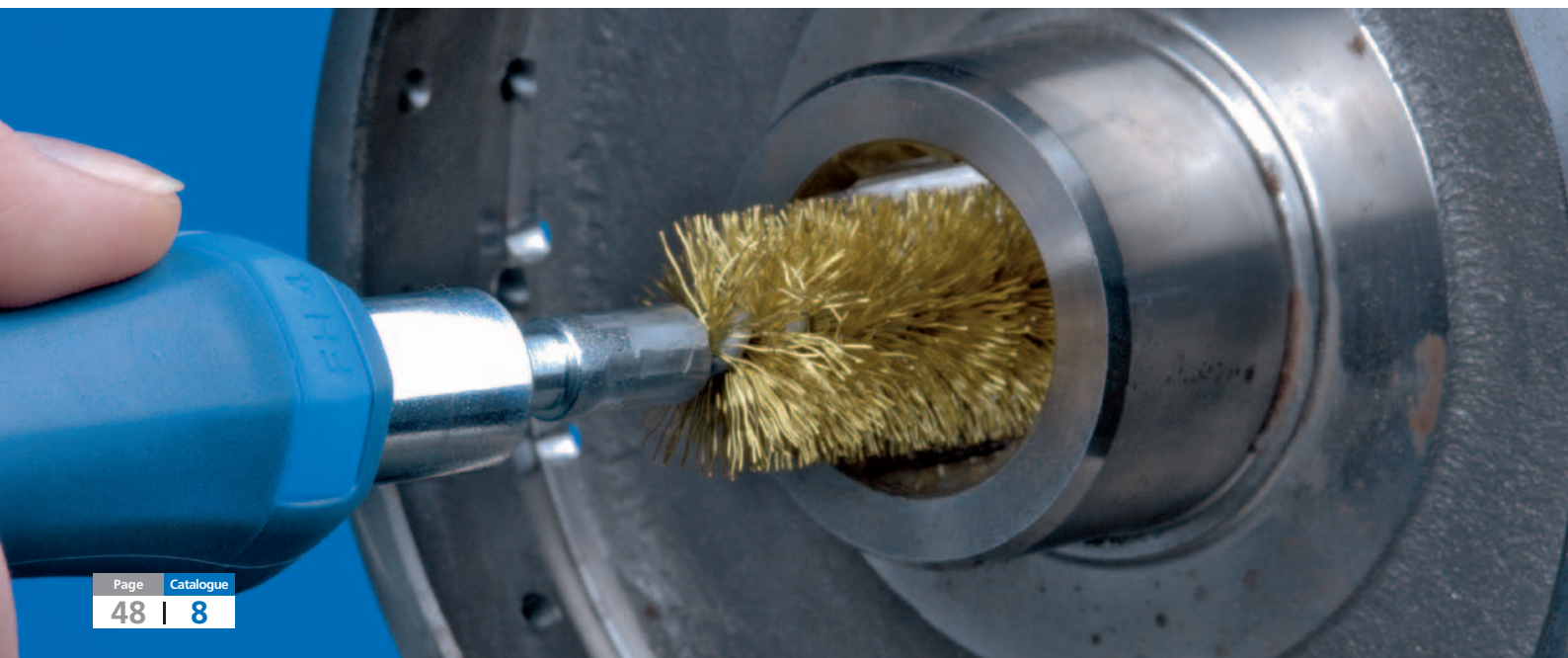

### Quick-change handle SWG

Suitable for manual work with tube brushes.

The SWG-6 quick-change handle can be used with all group 10 collets to clamp additional shank diameters. Detailed information and ordering data can be found in catalogue section 9 "Tool drives".

#### Advantages:

- Comfortable to use thanks to ergonomic shape.

#### Recommendations for use:

- Combine with the IBUV extensions in order to access hard-to-reach areas. The available length combinations can be found below.

#### Ordering notes:

- Please complete the description with the desired thread.
- BSW = British Standard Whitworth

#### PFERDVALUE:



L [mm]	Thread				IP	Description
	M6	3/8 BSW	1/2 BSW	Collet 6 mm		
	EAN 4007220					
135	721803	723036	749333	-	1	SWG-...
150	-	-	-	723043	1	SWG-6

### Extension IBUV, wire stem IBUS

Suitable for work with tube brushes with a thread. Please note the outer diameter of the screw socket:

- M6 = 12 mm
- 3/8 = 12 mm
- 1/2 = 16 mm

Extension	SWG [mm]	IBUS 300 [mm]	IBUV 1000
without	135	300	1,000
IBUV 300	435	600	1,300
IBUV 1000	1,135	1,300	2,000

#### Advantages:

- Optimal access to hard-to-reach areas.

#### Recommendations for use:

- To achieve a larger overall length, combine the IBUV extensions and IBUS wire shanks with one another or with the SWG quick-change handles.

#### Ordering notes:

- Please complete the description with the desired thread.

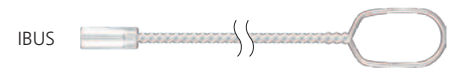

L [mm]	Thread			IP	Description
	M6	3/8 BSW	1/2 BSW		
	EAN 4007220				
300	726884	726891	750032	1	IBUV ... 300
1,000	660782	660799	750049	1	IBUV ... 1000
300	726907	726914	750094	1	IBUS ... 300
1,000	660805	660812	750100	1	IBUS ... 1000

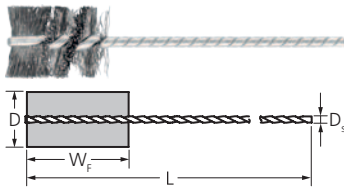

### IBU, shank-mounted

For light cleaning and deburring work on threaded holes or recesses, e.g. keyways.

#### Advantages:

- Highly flexible, enabling optimal adjustment to the workpiece contour.
- Longer tool life due to the design of the rotating wire.

#### Recommendations for use:

- Insert into the workpiece before it starts to rotate.
- Use with clockwise rotation.

#### Ordering notes:

- Please complete the description with the desired filament material and filament material diameter ( $D_f$ ).

#### Safety notes:

- When using tube brushes inside pipes, holes, grooves, etc., deviations from the specified maximum permitted rotational speed are possible in consultation with PFERD.

D [mm]	W <sub>F</sub> [mm]	D <sub>S</sub>	L [mm]	Filament material / D <sub>F</sub> [mm]				Max. RPM		Description
				Steel 0.12	Steel 0.20	INOX 0.12	INOX 0.20			
				EAN 4007220						
6	25	3.2	90	036761	-	036938	-	3,500	10	IBU 0625/3,2 ...
8	25	3.2	90	036778	-	-	-	3,500	10	IBU 0825/3,2 ...
10	25	3.2	90	036785	036853	037065	-	3,500	10	IBU 1025/3,2 ...
13	25	3.2	90	036792	036860	036952	-	3,500	10	IBU 1325/3,2 ...
16	25	3.2	90	036808	036877	036969	037003	3,000	10	IBU 1625/3,2 ...
19	25	3.2	90	036815	036884	036976	037010	3,000	10	IBU 1925/3,2 ...
22	25	3.8	90	036822	036891	036983	-	3,000	10	IBU 2225/3,8 ...
25	25	3.8	90	036846	036907	036990	037027	3,000	10	IBU 2525/3,8 ...
29	25	3.8	90	-	036914	-	-	3,000	10	IBU 2925/3,8 ...
32	25	3.8	90	-	036921	-	037034	3,000	10	IBU 3225/3,8 ...

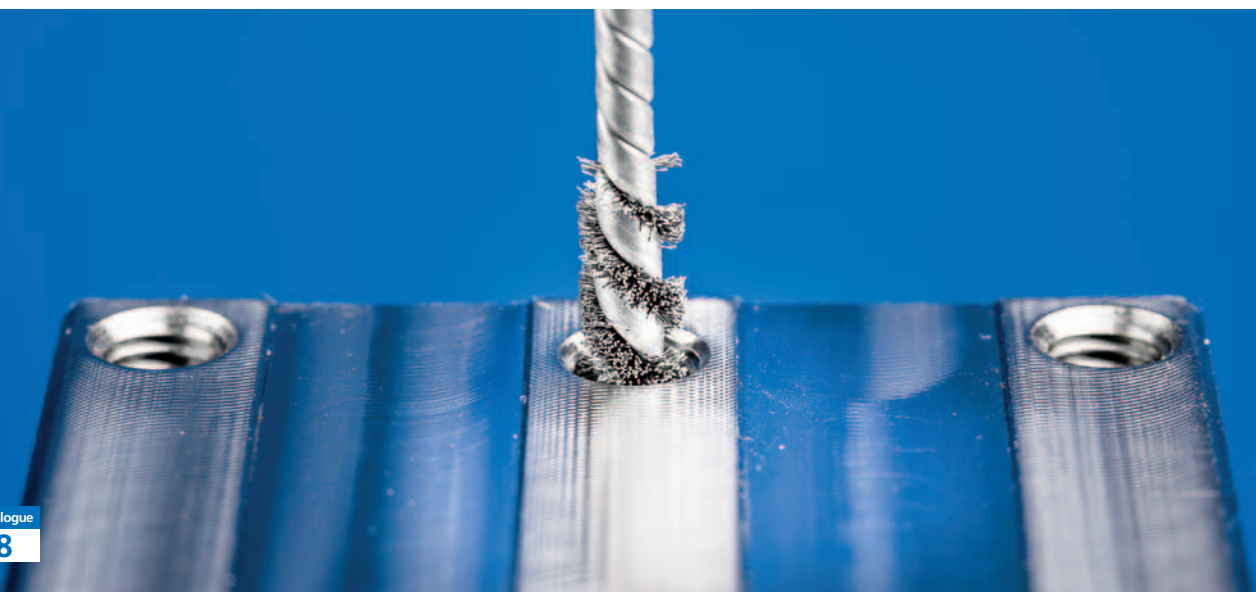



## IBU, shank-mounted

For deburring and cleaning holes and cross holes.

### Advantages:

- Enable outstanding precision and efficiency in work on delicate workpieces.
- Highly flexible, enabling optimal adjustment to the workpiece contour.
- The dimensional accuracy of the workpieces remains unchanged.

### Safety notes:

- When using tube brushes inside pipes, holes, grooves, etc., deviations from the specified maximum permitted rotational speed are possible in consultation with PFERD.

### Recommendations for use:

- Insert into the workpiece before it starts to rotate.
- Use with clockwise rotation.

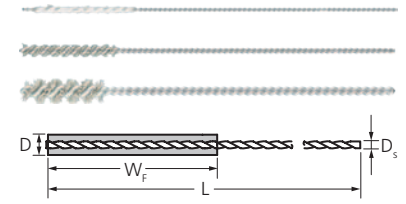

D [mm]	W <sub>F</sub> [mm]	D <sub>S</sub> [mm]	D <sub>F</sub> [mm]	L [mm]	Packaging	Max. RPM	Description
					 EAN 4007220		

### Aluminium oxide (AO) 2000 plastic filament

0.7	12	0.4	0.20	100	037089	1,000	IBU 0,712/0,4 AO 2000 0,20
-----	----	-----	------	-----	--------	-------	----------------------------

### Silicon carbide (SiC) 1000 plastic filament

1.2	12	0.5	0.25	100	037096	1,000	IBU 1,212/0,5 SiC 1000 0,25
1.9	18	0.7	0.25	100	037102	1,000	IBU 1,918/0,7 SiC 1000 0,25
2.2	18	0.9	0.25	100	037119	1,000	IBU 2,218/0,9 SiC 1000 0,25
2.6	25	1	0.25	100	037133	1,000	IBU 2,625/1,0 SiC 1000 0,25
3.2	25	1.7	0.25	100	037164	1,000	IBU 3,225/1,7 SiC 1000 0,25
3.5	25	1.7	0.25	100	037195	1,000	IBU 3,525/1,7 SiC 1000 0,25

### Aluminium oxide (AO) 600 plastic filament

4.2	25	2.2	0.30	125	037218	1,000	IBU 4,225/2,2 AO 600 0,30
4.8	25	2.2	0.30	125	037225	1,000	IBU 4,825/2,2 AO 600 0,30
5.5	25	2.2	0.30	125	037249	1,000	IBU 5,525/2,2 AO 600 0,30
6.6	25	2.9	0.30	125	037263	1,000	IBU 6,625/2,9 AO 600 0,30
8.2	25	2.9	0.30	125	037270	2,000	IBU 8,225/2,9 AO 600 0,30
9.8	25	3.2	0.30	125	037294	2,000	IBU 9,825/3,2 AO 600 0,30
11.5	25	3.2	0.30	125	037317	2,000	IBU 11,525/3,2 AO 600 0,30
13	25	3.7	0.30	125	037324	2,000	IBU 1325/3,7 AO 600 0,30
16	25	3.7	0.30	125	037386	2,000	IBU 1625/3,7 AO 600 0,30
20	25	4.7	0.30	125	037393	2,000	IBU 2025/4,7 AO 600 0,30
25	25	4.7	0.30	125	037409	2,000	IBU 2525/4,7 AO 600 0,30

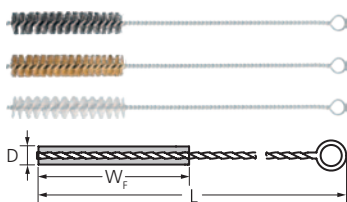

### IBU, with eyelet

Specially suited to brushing in manual applications.

#### Advantages:

- Enable outstanding precision and efficiency in work on delicate workpieces.
- Optimal access to hard-to-reach areas such as the inner surfaces of pipes and drilled holes.

#### Ordering notes:

- Please complete the description with the desired filament material and filament material diameter ( $D_f$ ).

D [mm]	W <sub>F</sub> [mm]	L [mm]	Filament material / D <sub>f</sub> [mm]										IP	Description
			Steel 0.10	Steel 0.15	INOX 0.10	INOX 0.15	Brass 0.10	Brass 0.15	Nylon 0.10	Nylon 0.15	Nylon 0.20	Nylon 0.30		
EAN 4007220														
3	100	300	035740	-	036198	-	036570	-	036617	-	-	-	10	IBU 03100 ...
4	100	300	-	035801	-	036501	-	036587	-	036624	-	-	10	IBU 04100 ...
5	100	300	-	035993	-	036426	-	036594	-	036631	-	-	10	IBU 05100 ...
6	100	300	-	748923	-	748930	-	748947	-	-	748961	-	10	IBU 06100 ...
8	100	300	-	748985	-	748992	-	749005	-	-	749012	-	10	IBU 08100 ...
10	100	300	-	749036	-	749050	-	749043	-	-	749067	-	10	IBU 10100 ...
12	100	300	-	749074	-	749081	-	749098	-	-	-	749104	10	IBU 12100 ...
15	100	300	-	749111	-	749128	-	749142	-	-	-	749159	10	IBU 15100 ...
18	100	300	-	036082	-	036563	-	036600	-	-	-	036648	10	IBU 18100 ...
20	100	300	-	749166	-	749173	-	749180	-	-	-	749197	10	IBU 20100 ...
25	100	300	-	749203	-	749210	-	749227	-	-	-	749708	10	IBU 25100 ...
30	100	300	-	749241	-	749258	-	749265	-	-	-	749272	10	IBU 30100 ...



PFERD offers an extensive range of scratch brushes with various shapes and filament materials.

### Advantages:

- Optimum presentation on the **PFERD**TOOL-CENTER using hanging hole and labelling with EAN number, description and filament material.

### Ordering note:

- Please complete the description with the desired filament material and filament diameter.



### HBU, universal use

General-use scratch brush for all light cleaning and rust removal jobs.

Rows	L <sub>T</sub> [mm]	L [mm]	Filament material			IP	Description
			Steel 0.35	INOX 0.30	Brass 0.30		
EAN 4007220							
1	25	290	659489	659496	-	10	HBU 10 ...
2	25	290	572191	572221	572528	10	HBU 20 ...
3	25	290	572207	572238	572535	10	HBU 30 ...
4	25	290	572214	572245	572542	10	HBU 40 ...
5	25	290	153741	572252	572559	10	HBU 50 ...
6	25	290	713341	713365	-	10	HBU 60 ...
Bulk pack							
3	25	290	808320	-	-	50	HBU 30 GP ...
4	25	290	808337	808351	-	50	HBU 40 GP ...
5	25	290	808344	-	-	50	HBU 50 GP ...



### HBU LH, Long Handle

Suitable for cleaning, derusting, and cleaning of weld seams and surfaces. Extra-long handle.

Rows	L <sub>T</sub> [mm]	L [mm]	Filament material	IP	Description
			Steel 0.35		
EAN 4007220					
3	25	350	616840	10	HBU LH 30 ...
4	25	350	616857	10	HBU LH 40 ...



### HBK, for fillet welds

Suitable for cleaning and derusting fillet welds and V-shaped welds thanks to the V shape.

Rows	L <sub>T</sub> [mm]	L [mm]	Filament material		IP	Description
			Steel 0.35	INOX 0.35		
EAN 4007220						
3	35	290	572481	572498	10	HBK 30 ...



### HBG, curved

Excellent for cleaning work in hard-to-reach areas, e.g. angles, corners and pipes. Steel = brass-plated steel wire.

Rows	L <sub>T</sub> [mm]	L [mm]	Filament material			IP	Description
			Steel 0.30	INOX 0.30	Brass 0.30		
EAN 4007220							
1	25	265	153727	153734	572672	10	HBG 10 ...







### HBUP, plastic body

Universally suitable for all light cleaning and derusting work. The version with a stainless steel filament is approved for use in the foodstuff industry.

#### Advantages:

- Safe and ergonomic working thanks to curved two-component handle.

Rows	L <sub>T</sub> [mm]	L [mm]	Filament material			IP	Description
			Steel 0.40	INOX 0.40	Brass 0.30		
			EAN 4007220				
1	25	290	906583	906743	-	10	HBUP 10 ...
2	25	290	906590	906750	906712	10	HBUP 20 ...
3	25	290	906644	906767	906729	10	HBUP 30 ...
4	25	290	906651	906774	906736	10	HBUP 40 ...
5	25	290	906705	906781	-	10	HBUP 50 ...



### HBZ, for spark plugs

Particularly suited to cleaning spark plugs, small workpieces and tools.

Rows	L <sub>T</sub> [mm]	L [mm]	Filament material	IP	Description
			Brass 0.15		
			EAN 4007220		
3	15	145	572566	10	HBZ 30 ...



### HBB, block brushes with a handle

Wire brush with handle for general cleaning work on large surfaces.

Rows	L <sub>T</sub> [mm]	L [mm]	Filament material	IP	Description
			Steel 0.45		
			EAN 4007220		
8	35	235	647295	12	HBB 80 ...

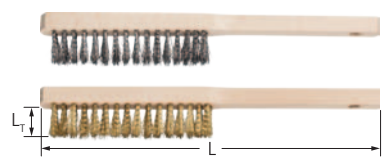

### HBFM, for precision mechanics

Excellent for light brushing on fine surfaces. The filament material diameter of 0.15 mm allows a smooth brushing action and produces a fine surface.

Rows	L <sub>T</sub> [mm]	L [mm]	Filament material			IP	Description
			Steel 0.15	INOX 0.15	Brass 0.15		
			EAN 4007220				
4	20	220	659502	659519	659526	10	HBFM 40 ...

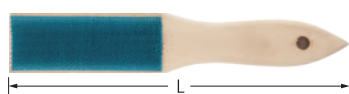

### HBF, for files

Suitable for cleaning files.

Rows	L <sub>T</sub> [mm]	L [mm]	Filament material	IP	Description
			Steel		
			EAN 4007220		
1	7	232	015315	5	HBF 10 ST 0,15

To enable brushes with arbor holes to be used on tool drives with collets, PFERD supplies a corresponding arbor for each brush type.

**Advantages:**

- Secure hold of the brush thanks to highly accurate fit.

**Examples of brushes with arbors**



**BO**

Enables the use of wheel and composite disc brushes with an arbor hole on tool drives with a collet, e.g. electric straight grinders and flexible shaft drives.

**Safety notes:**

- Arbors must only be used for brush diameters up to a maximum of 200 mm.

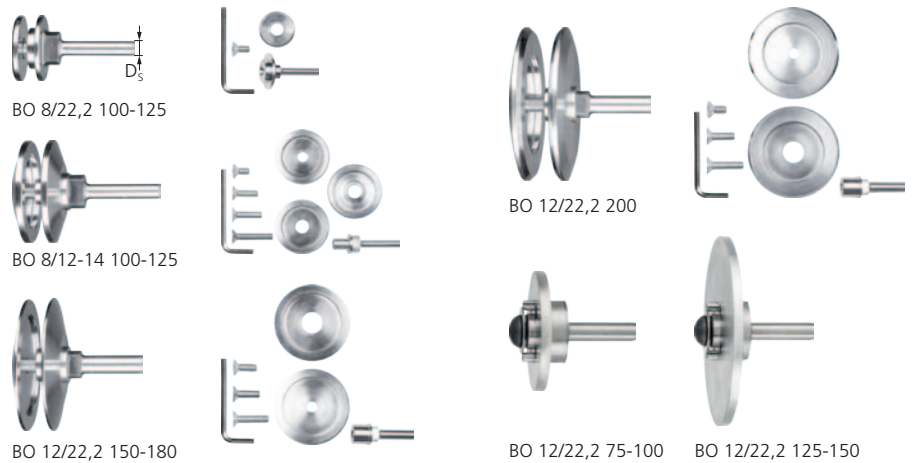

D <sub>s</sub> [mm]	Suitable for brush diameter	Suitable for hole diameter D <sub>A</sub> / D <sub>M</sub>	Suitable for	Page	EAN 4007220	IP	Description
---------------------	-----------------------------	--	--------------	------	-------------	----	-------------

**Arbors for wheel brushes**

8	100–125	12/14	Wheel brushes, crimped (RBU)	22, 24, 25	107843	1	BO 8/12-14 100-125
		22.2	Wheel brushes, knotted (RBG)	18, 19, 20, 21, 42	751930	1	BO 8/22,2 100-125
12	150–180	22.2	Wheel brushes, crimped (RBU), Wheel brushes, knotted (RBG)	18, 19, 20, 21, 22, 24, 25, 27	107850	1	BO 12/22,2 150-180
	200	22.2	Wheel brushes, crimped (RBU), Wheel brushes, knotted (RBG)	21, 22, 23, 24, 25, 27, 28	107867	1	BO 12/22,2 200

**Arbors for composite disc brushes**

12	75–100	22.2	Composite disc brushes (DBU)	29, 30	808887	1	BO 12/22,2 75-100
	125–150	22.2	Composite disc brushes (DBU)	29, 30	808894	1	BO 12/22,2 125-150

**BO, POLISCRATCH**

For attaching POLISCRATCH brushes to straight grinders, flexible shafts or power drills.

**Safety notes:**

- Exclusively for use with POLISCRATCH brushes.



D <sub>T</sub>	D <sub>s</sub> [mm]	Suitable for	Page	EAN 4007220	IP	Description
M14x2	8	Wheel brushes crimped (RBU), POLISCRATCH type	17	900482	1	BO 8/M14

PFERD offers various adapter sets for wheel brushes with arbor holes.

### Advantages:

- Brushes can be used on all tool drives as the hole diameter is adjusted to the required dimension.
- Secure hold of the brush thanks to highly accurate fit.

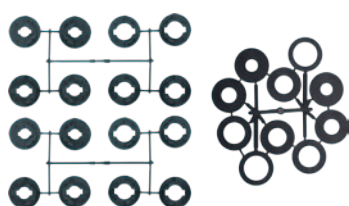

### Adapter set AK 32 and AK 32-2

**AK 32:** Suitable for wheel brushes with a brush diameter as from 150 mm in the narrow type.

**AK 32-2:** Suitable for wheel brushes with a brush diameter as from 150 mm in the wide type.

#### Recommendations for use:

- Use for applications that produce little heat and require little pressure.

Suitable for	Page	Hole diameter $D_A$ included [mm/inches]	EAN 4007220	IP	Description
RBU, narrow face $\geq$ dia. 150 mm	22	20.0 / 18.0 / 14.0 / 12.0 / 25.4 (1) / 22.2 (7/8) / 16.0 (5/8) / 12.7 (1/2)	608593	1	AS AK 32
RBU, wide face $\geq$ dia. 150 mm	24, 25	31.75 / 20.0 / 18.0 / 14.0 / 12.0 / 25.4 (1) / 22.2 (7/8) / 19.2 (.750) / 16.0 (5/8) / 12.7 (1/2)	806890	1	AS AK 32-2



### Adapter pairs AM 50.8 and APM 50.8

**AM 50.8:** Suitable for wheel brushes with a brush diameter as from 150 mm in the wide and composite type.

**APM 50.8:** Suitable for knotted wheel brushes with a diameter of 200–250 mm and crimped wheel brushes designed as deburring types.

#### Recommendations for use:

- Particularly suitable for applications which produce a lot of heat and involve high pressure.

#### Ordering notes:

- **AM 50.8:** A set consists of 2 individual adapters.
- **APM 50.8:** A set consists of 3 adapter pairs.

Suitable for	Page	Hole diameter $D_A$ included [mm/inches]	EAN 4007220	IP	Description
RBU, wide type, $\geq$ dia. 150 mm, RBUP, composite type, $\geq$ dia. 150 mm	24, 25, 27, 28	14.0	549803	1	AP AM 50,8/14,0
		16.0	548486	1	AP AM 50,8/16,0
		20.0	549834	1	AP AM 50,8/20,0
		22.2	806906	1	AP AM 50,8/22,2
		25.4	548509	1	AP AM 50,8/25,4
		30.0	806913	1	AP AM 50,8/30,0
		32.0	606605	1	AP AM 50,8/32,0
RBG, knotted wheel brushes, dia. 200–250 mm, RBU, deburring brush type, dia. 200–250 mm	21, 23, 26	16.0/18.0/20.0	900376	1	APM 50,8/16-20
		22.2/25.4/30.0	900390	1	APM 50,8/22,2-30
		32.0/35.0/40.0	900406	1	APM 50,8/32-40